



Dough Processing Equipment & Ovens Since 1976

TYM 2000 Series

ECENTRIC DOUGH ROUNDER MACHINE



The company reserves its rights for technical modifications for development ©2018 ÖNDERMAK TECHNICAL SERVICE. All Rights Reserved. Transfer of product-specific information to third parties is prohibited. The data and pictures in this manual may show changes , the manufacturer reserves the right





The company reserves its rights for technical modifications for development ©2018 ÖNDERMAK TECHNICAL SERVICE. All Rights Reserved. Transfer of product-specific information to third parties is prohibited. The data and pictures in this manual may show changes , the manufacturer reserves the right

ÖNDERMAK Industrial Bakery Automations and Ovens

Eskişehir OSB 8. Cad. No:11 26110 Eskişehir /Türkiye

Pbx. | + 90 222 236 08 02

Whatsapp | + 90 532 722 02 78

Mail | bilgi@ondermak.com.tr

Web | www.ondermak.com.tr

Content

Content.....	3
About The Machine.....	6
Technical Data.....	7
Transport.....	9
Electrical Connection and Warnings.....	12
First Installation.....	14
Start-Up.....	15
Using Manual.....	17
Control Panel.....	18
General Points.....	19
Cleaning & Daily Maintenance.....	20
General Maintenance.....	20
Spare Part List I.....	21
Spare Part List II.....	22
Malfunctions.....	23
General Rules.....	24
Warranty.....	25
Electric Schema.....	26
CE Document.....	27
Notas.....	27
Notes.....	28

Dear Valued Customer,

We would like to express our sincere gratitude for your purchase of the high-quality TYM 2000 Eccentric Rounder Machine, manufactured by Ondermak. We are delighted to provide you with this comprehensive guide to help you maximize the potential of your new and exciting product. Within this guide, you will find clear, concise instructions, valuable tips, and all the essential information necessary to ensure a smooth and satisfactory experience from the outset.

This guide will offer you a detailed overview of the key features and functions of the TYM 2000. We will also explain how our product can enhance your operations and meet your specific needs.

Before you begin using your TYM 2000, it is crucial to familiarize yourself with the necessary requirements and preparations for its proper installation and setup. We will walk you through the steps to ensure that everything is in place before you begin.

The TYM 2000 Product Manual is an essential tool to help you fully benefit from the capabilities and advantages of our product. Our primary objective is to ensure that you have a seamless experience from the very first use and are able to derive the maximum value from your purchase. Should you have any questions or require further assistance, please do not hesitate to contact us.

Thank you for choosing the TYM 2000.

Best Regards

Ondermak

ONDERMAK Industrial Bakery Automations and Ovens

Eskişehir OSB 8. Cad. No:11 26110 Eskişehir /Türkiye

Pbx. | + 90 222 236 08 02

Whatsapp | + 90 532 722 02 78

Mail | bilgi@ondermak.com.tr

Web | www.ondermak.com.tr

All products are labeled as follows, where you can find all the details about your model

 Eskişehir ÖNDERMAK ENDÜSTRİYEL MAKİNA OTOMASYON SAN. TİC. LTD. ŞTİ.			
CE			
Ürün No Model	<input type="text"/>	İşletme Gerilimi Electricity Supply	<input type="text"/>
Motor Gücü Motor Power	<input type="text"/>	Seri No Serial Nr.	<input type="text"/>
Kapasite Capacity	<input type="text"/>	İmalat Yılı Manufact Year	<input type="text"/>
Koruma Sınıfı Protection Class	<input type="text"/>	<u>Made In Turkey</u>	
Eskişehir Osb 8. Cad. No: 11 26110 Eskişehir/TURKEY Tel: +90 222 236 08 02 www.undermak.com.tr			

ÖNDERMAK ENDÜSTRİYEL OTOMASYON SAN.TİC.LTD.ŞTİ - ESKİŞEHİR

Eskişehir OSB 8. Cad. No:11 26110 Eskişehir - TURKEY

Tel:00 90 222 236 08 02

Fax:00 90 222 236 08 03

www.undermak.com.tr

bilgi@undermak.com.tr

About The Machine

The **eccentric dough rounder machine** is designed to efficiently shape dough into uniform, round pieces, ensuring consistent quality for baking. It utilizes a specialized eccentric mechanism to evenly and gently round the dough, which is essential for achieving uniform texture and proper fermentation.

Key Components and Functioning

1. **Dough Inlet:** The dough is fed into the machine via an inlet, typically positioned at the left front. The dough is usually divided into portions either manually or through an integrated divider.
2. **Eccentric Mechanism:** At the core of the machine is the **eccentric cam system**, (gear system) which drives the motion of the rounding rollers. This cam system generates a unique rotary motion that guides the dough portions through a series of rollers, applying gentle pressure to round each piece without overworking the dough.
3. **Rounding Rollers:** The dough passes through a set of **rounding rollers** that progressively shape it into a uniform ball. The eccentric movement of the rollers ensures that the dough is rounded smoothly and consistently.
4. **Adjustable Settings:** The machine typically features adjustable settings for the speed and intensity of the rounding process. This allows the operator to customize the machine's operation based on dough type and desired results.
5. **Exiting the Machine:** Once rounded, the dough pieces exit the machine and are ready for further processing, such as resting, proofing, or baking. The uniformity of the dough pieces ensures more even baking, contributing to consistent product quality.
6. **Artisan Bread & Dough:** The machine has been specifically designed for rounding artisan breads, large batches, and custom recipe doughs that require a more hands-on, artisanal approach. Thanks to the drum and cone Teflon coating, it ensures the best results, maintaining the delicate texture and quality of the dough while achieving consistent round shapes.

Technical Data

Kapasite / Capacity / Capacidad	Adet/sa. - Pcs/hr.	2000
Yuvarlama Aralığı / Dough Range / Masa Peso	gr.	50-4000
Genişlik (W) / Width / Ancho	mm	920
Uzunluk (L) / Length / Largo	mm	1100
Yükseklik (H) / Height / Alto	mm	1265
Hamur Giriş Yüksekliği (H1) / Dough Input / Masa Entrada	mm	1700
Hamur Çıkış Yüksekliği (H2) / Dough Output / Masa Salida	mm	1100
Elektrik Gücü / Electric Power / Energia	Kw	0,75
Elektrik Bağlantı / Elec.Connection / Elec. Conexión	Volt-Vac/Hz	380 400 v/50-60hz 3 +NPE
Ağırlık / Weight / Peso Neto	Kg	260
Materyal / Material	Paslanmaz	Stainless Steel/Inox

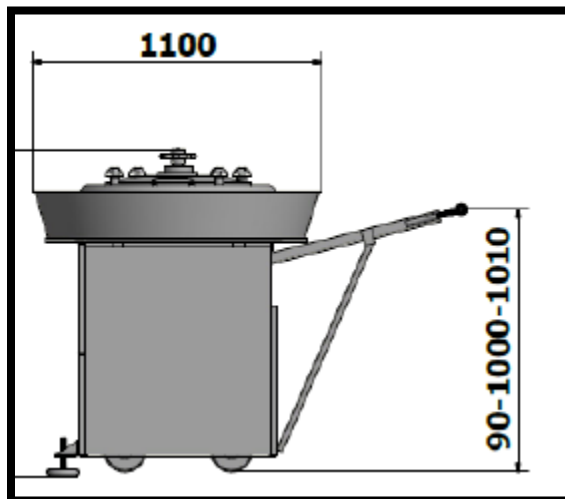
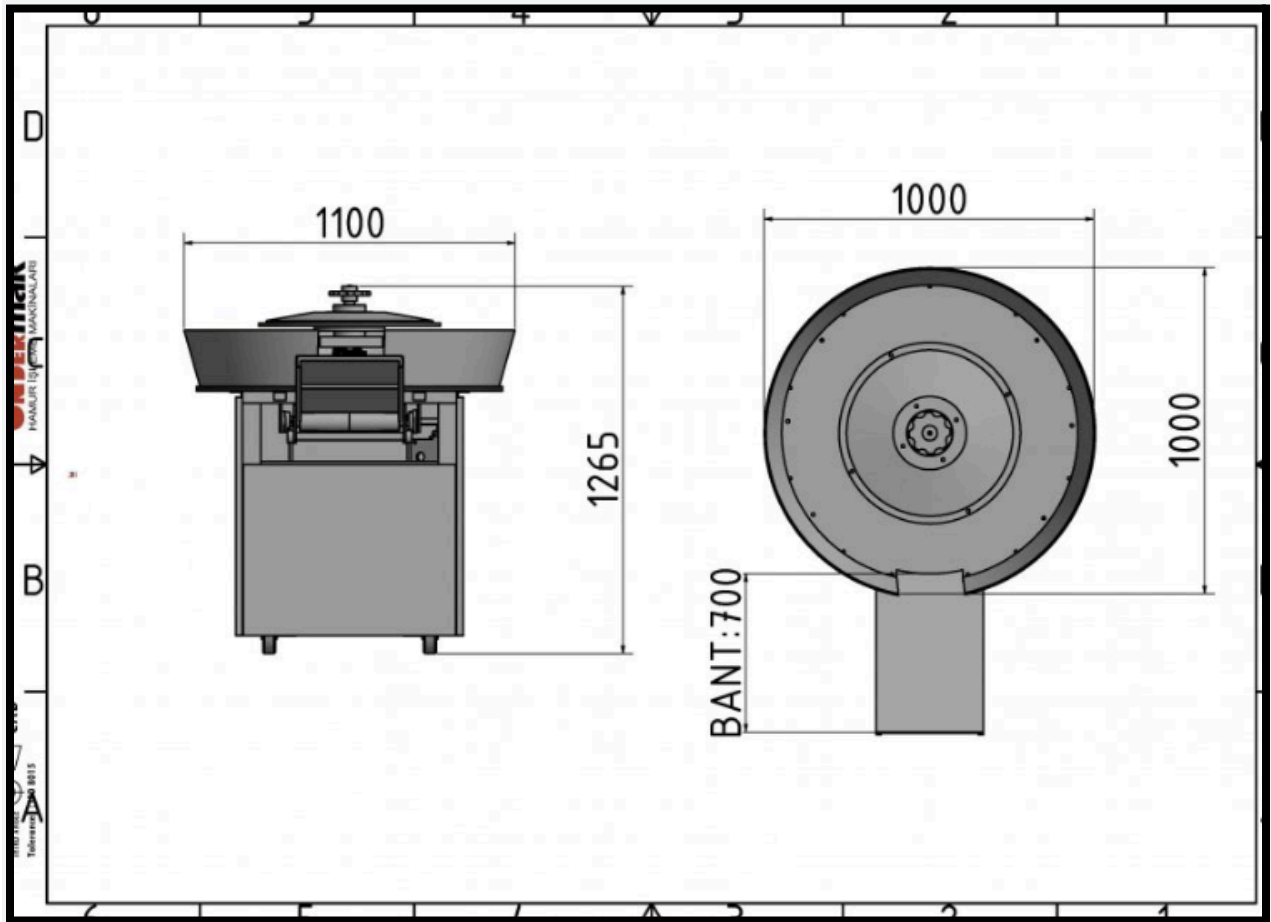

Transport

Storage Guidelines

The machine must be stored indoors, away from dust, moisture, and heat. The permissible environmental values for storage are as follows:

- Temperature: -5°C to 45°C
- Maximum humidity: 60%

It is essential to ensure that the storage area poses no risk of vehicle collisions. Protected parts should be regularly checked. Do not stack machines on top of each other. If the machine is stored without packaging, it should be raised off the floor using wooden pallets and covered to prevent the accumulation of dust and dirt.

Shipping Methods

The machine can be shipped in the following configurations:

- Fully assembled;
- Partially assembled;
- Not fully assembled; parts are stacked on a pallet or optionally on any wooden structure.

The transport vehicle must have the required lifting capacity (please refer to the machine's technical data). The lifting device used to elevate the machine should have sufficient lifting capacity and fork length.

Product Transport

Equipment and Tools for Transporting and Lifting the Machine:

If the machine is on a box or pallet:

- The forklift must have sufficient capacity. Or,

- Cranes and their equipment (ropes, straps, or chains) must have sufficient capacity if there are transport points on the machine.

If the machine is not packaged:

- The forklift must have sufficient capacity. Or;
- If transport points are available on the machine, the crane and its equipment (rope, strap, or chains) must have sufficient capacity.

The machine's wheels allow it to move smoothly across a flat floor. The machine can also be transported on the pallet or using a chain mounted from the top of the machine.

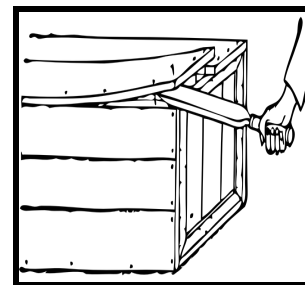
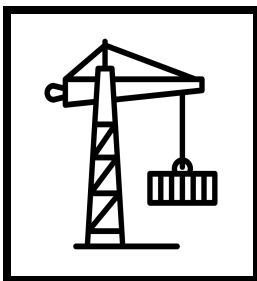

General Guidelines for Lifting and Transporting the Machine

- Before starting the operation, designate and inspect the entire transport area, the vehicle parking area, and the area where the machine will be installed. Ensure that there are no hazardous situations.
- Ensure that the vehicle used for the lifting and transport procedure has sufficient lifting capacity. The weights are marked on the packaging and/or are available in this manual.
- Check that the lifting cables and chains are approved and that the capacity indicated by the manufacturer is clearly written on the cables. Inspect the lifting cables for any damage or corrosion before use.
- Do not knot or twist the lifting cables, and follow the rules provided by the manufacturer in this manual.
- The same rules apply to chains and straps. Special attention should be paid to the central lifting of the machine.
- Do not pass over or under the machine when it is loaded and in motion.
- Ensure that no unauthorized personnel are in the loading area.
- To prevent accidents and injuries, all operators must remain at a safe distance while the machine is being lifted.
- Special care should be taken to maintain the system's stability during the machine lifting procedures.
- After this point, chains and straps should preferably be used during the transport of the machine.

Caution: Take the necessary precautions during transport! Begin lifting procedures only after ensuring that the hangers are fully installed.

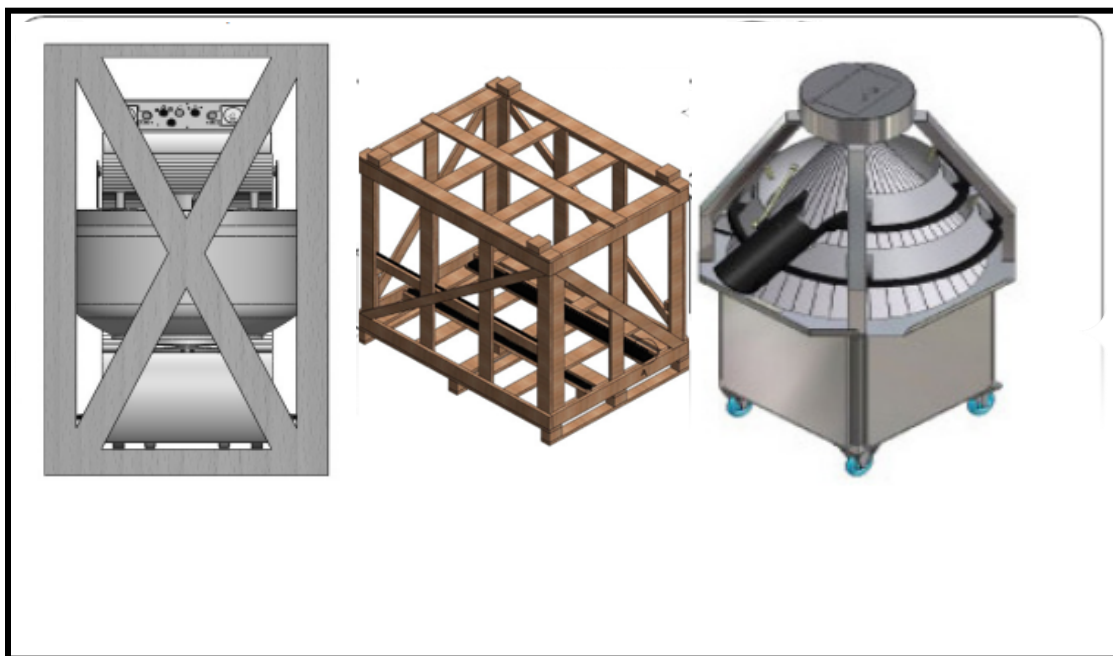

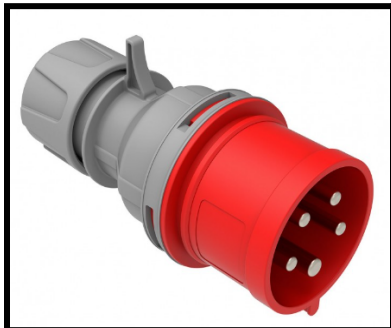

Electrical Connection and Warnings

- The electrical connection of the machine must be made in accordance with current regulations, and it is the responsibility of the customer.
- It is the customer's responsibility to maintain the electrical connections and circuits of the power supply.
- Use certified cables that are appropriate in length and suitable for the electrical panel.
- The power specifications can be found on the label information. Depending on the location of use, the length of the connection cables should be adjusted accordingly.
- Ensure that the power supply is disconnected before making the electrical connection.
- Cable routes should be properly established to avoid damage, and these areas should be covered to prevent any contact-related damage.



380/400 Volt 50/60 Hz 3NPE
European Standard

	<p>The electrical connection must be performed by qualified electricians.</p>
	<p>For safety, grounding must be applied on-site</p>



1. **Stretching Valve:** To adjust the dough stretching between drum and channel
2. **Handle for holding the drum up:** For cleaning the underside of the cone ,including the surface of plastic
3. **Control Unit:** (Emergency button, start/stop, speed variator)
4. **Stoppers:** To fix the machine to the floor
5. **Screws for Removing the drum:** For maintenance or cleaning
6. **Conveyor Belt**
7. **Main Switch (On/Off)**.....



8. **Flour Duster Unit (Optional)**.....



First Installation

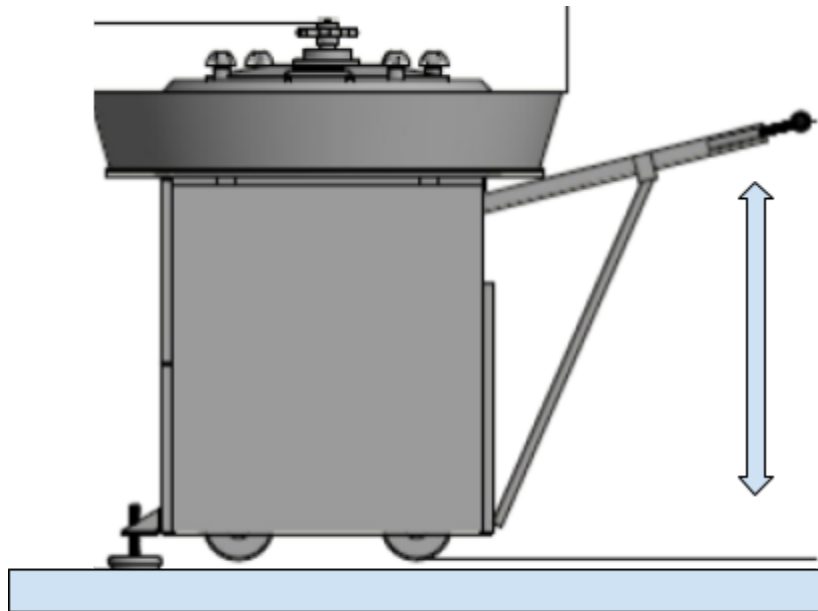

- The machine must be placed on a flat surface (must).
- Please do not forget to activate the wheel brakes or the floor fasteners.
- As indicated below, you can position the TYM and connect the plug.
- Adjust the conveyor belt height according to the desired output.



Start-Up

Before starting the machine for the first time, check the following points:

- Ensure the machine's structure is properly positioned and flat on the floor.
- Carefully unpack all coverings.
- Remove the cardboard and packaging bag from the machine.
- Remove the straps, taking special care when loosening them by cutting
- Ensure safety precautions around the machine.
- Remove the machine from the pallet. Make sure to do this with at least two people to lower it as gently as possible to the ground.
- Check that all parts and components have been correctly assembled and securely fastened.
- Ensure the electrical connections have been made properly according to all the warnings discussed, and check safety measures.**IMPORTANT:** This machine must be grounded.
- Place the metal plate on top for the package.
- Before connecting your machine to the electrical network and to avoid damaging the motor upon startup, it is important to verify that the electrical network matches the machine's specifications (refer to the machine's data plate). This machine complies with the Machinery Directives 2006/42, 2006/95, 2004/108 and carries the CE mark as proof of compliance.

	<p>All adjustments and installation must be carried out by a qualified person.</p>
	<p>In case of any questions, please contact the supplier.</p>



The dough rounder must rotate clockwise. If it rotates in the opposite direction, STOP immediately.

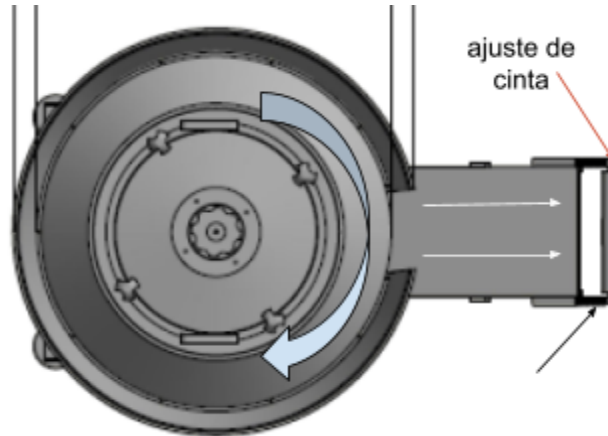

The conveyor belt must operate as indicated. There are arrow signs on the machine for guiding about rotation and directions



When starting the dough rounder, if it rotates in reverse, turn it off immediately and switch the polarity of the plug wires.

- ❖ Open the plug box.
- ❖ Only change the brown and black wires.

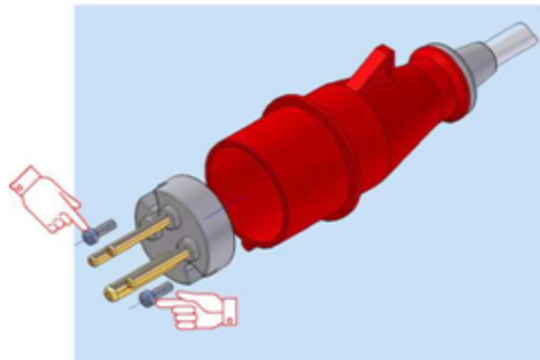

Using Manual

- Before the first use, clean the machine with a soft, damp cloth.
- Connect the power plug.
- Load the flour into the flour duster. Adjust the flour level (optional)
- Adjust the stretching valve and then do not forget to lock the orange bolt
- Place the dough by hand from the left side (fig. 1).
- It will automatically round the dough.
- Adjust the flour duster levels.
- Set the rounding speed using the variator.
- Set the lubrication level and position according to your preferences (*optional).
- The flour duster will activate automatically



	<p>It is strongly recommended that it be used by qualified persons</p>
	<p>Please do not place your hands inside while the machine is running</p>
	<p>Place the dough at intervals (every 3 seconds) to prevent them from sticking together.</p>

fig 1.



Control Panel

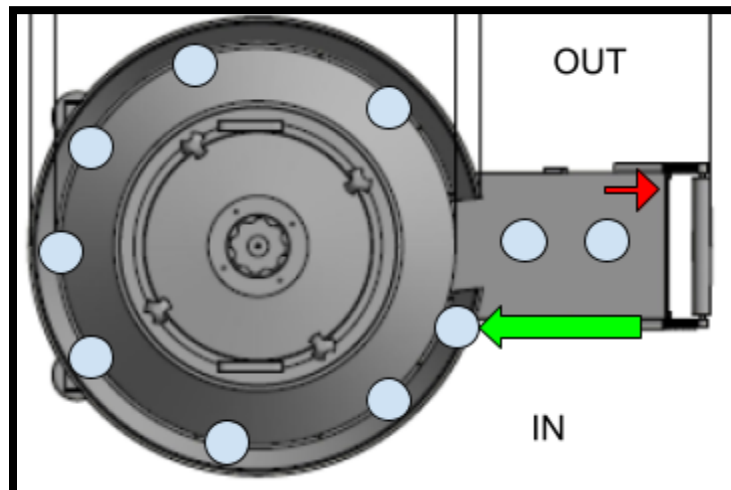
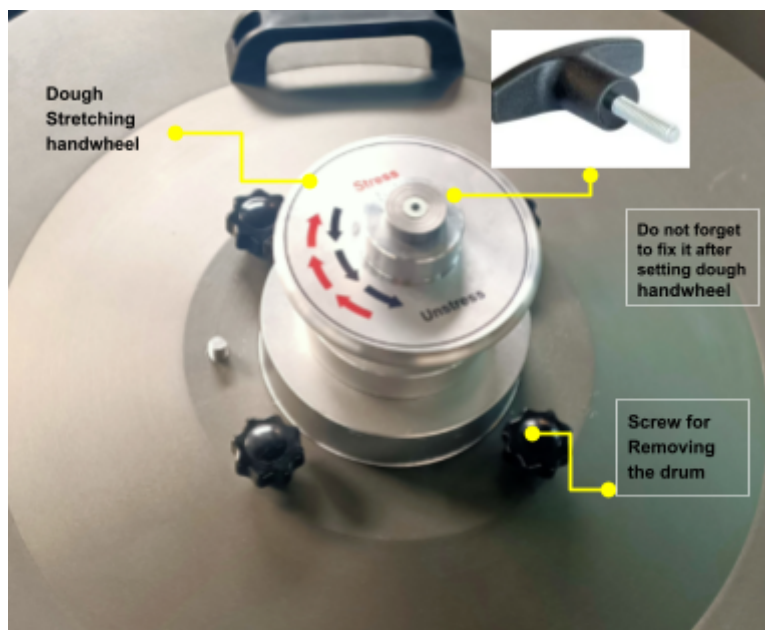
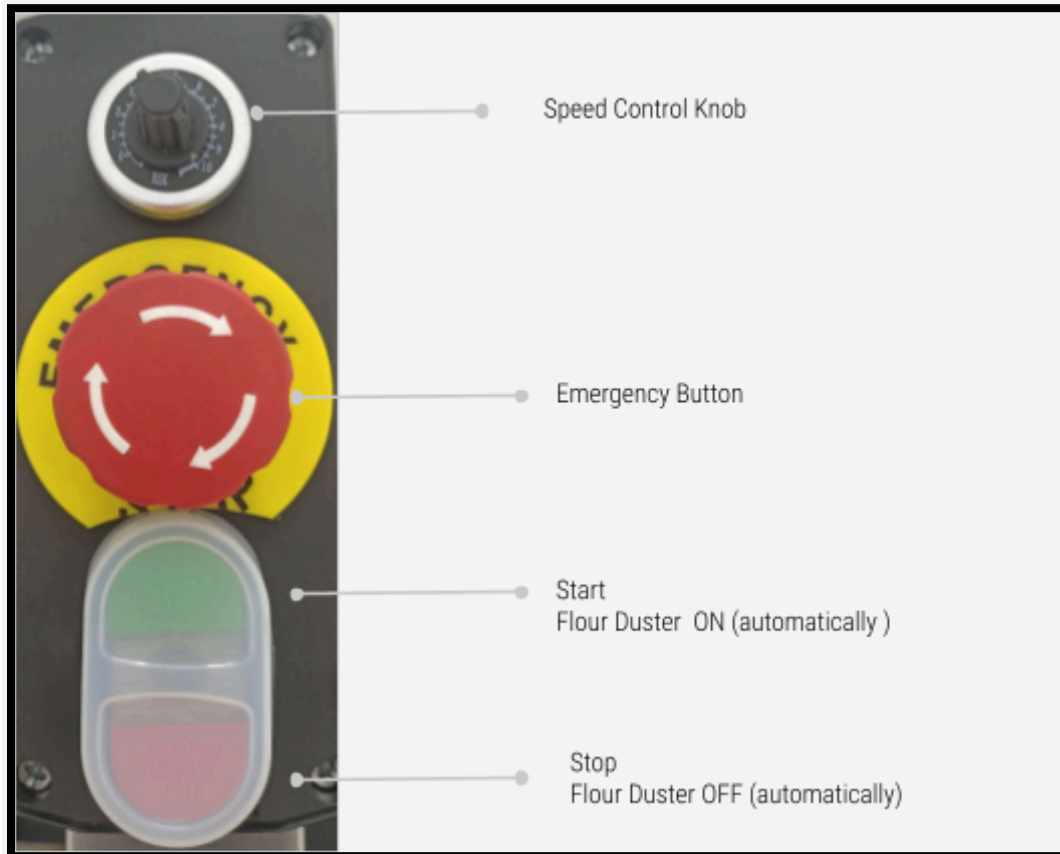

General Points

	<p>It is strongly recommended that the products be used by qualified personnel</p>
	<p>Please do not put your hands inside while the machine is operating.</p>
	<p>In case of danger to the user or the machine, use the main isolation switch to immediately disconnect the power supply</p>
	<p>Unplug the machine from the power outlet before performing any maintenance and/or service work.</p>
	<p>Clean and maintain the machine only after turning it off and disconnecting the power supply.</p>
	<p>Never use a knife or any sharp object on the surface.</p>
	<p>Any maintenance work or replacement of parts must be carried out by qualified personnel.</p>

Cleaning & Daily Maintenance

- Turn off the machine before performing any maintenance.
- Check if the crumb around drum, no leave dough pieces on surface
- Clean flour , dough cramps with a soft brush or plastic scraper.
- Use a dry cloth to clean the interior or exterior.
- Use a damp cloth to clean the exterior.
- NEVER USE A KNIFE OR ANY SHARP METAL OBJECT TO CLEAN

General Maintenance

- Turn off the machine before performing any tasks.
- Unplug the machine from the electrical supply.
- Remove the screws from the drum and clean underneath the cone every 2 months.
- Check the condition of the cone and the channels.
- If you notice any issues, contact your supplier.
- Sweep and clean (perhaps air vacuum) the interior of the machine.
- Check the condition of the bearings and lubricate them.
- Lubricate the actuator seals.
- Check the wheels and stoppers
- Check the PLC Inverter display if there any error code

Spare Part List I

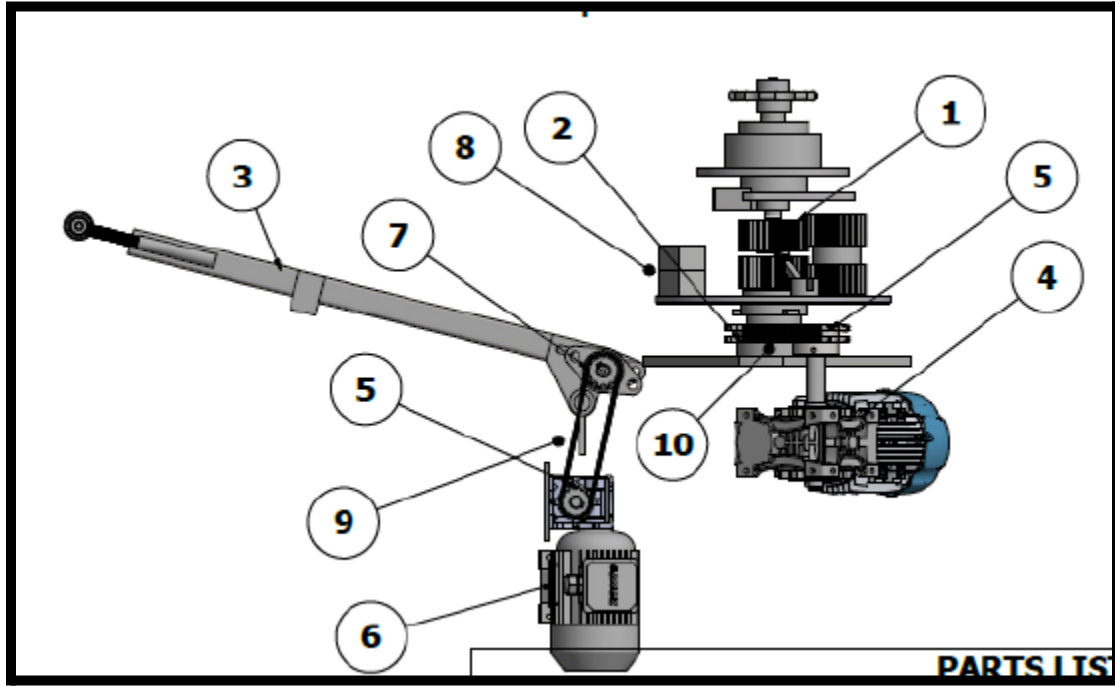

1	helix gear set
2	$\frac{5}{8}$ II 19 bearing
3	belt
4	motor 0.75Kw 1500 Rpm
5	$\frac{5}{8}$ II 25 bearing
6	motor conveyor 0.18 KW 1500 rpm
7	$\frac{1}{2}$ I 12 bearing
8	TYM support
9	$\frac{1}{2}$ I chain
10	$\frac{5}{8}$ II chain

Spare Part List II

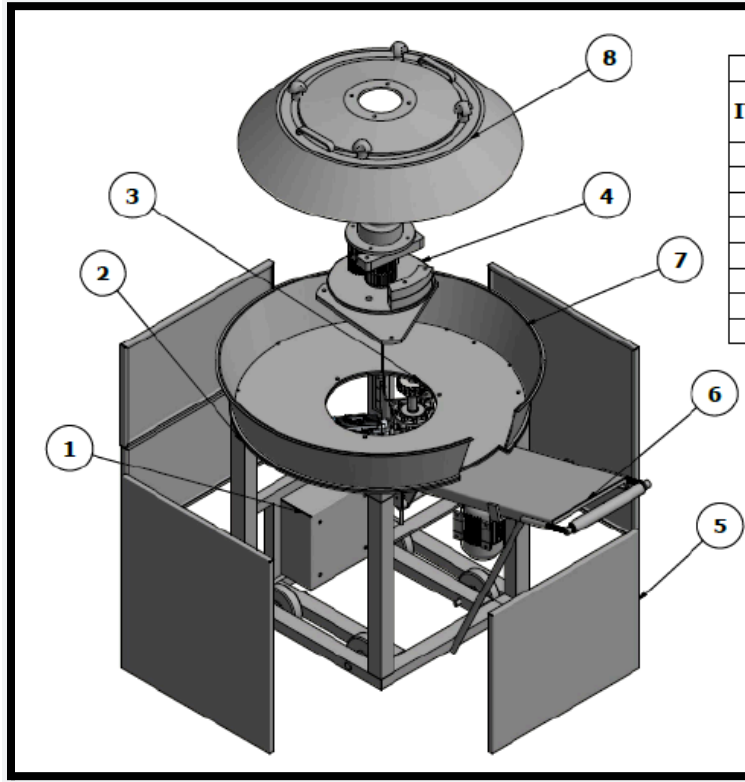













1	Electric Box
2	Profile Structure
3	Bottom Plastic Panel
4	Transmission Gear
5	Panels
6	Conveyor Roller
7	Rear Channel Teflon Coated
8	Drum Teflon Coated

Malfunions

Machine is not working	Check the connected cables
	Switch on emergency button
	Check the motor electric tension and current
	Control Danfoss PLC Inverter display if there any error code
Machine is working good but rounding well	Check the surface of the cone and the space between the channel wings for any dough crumbs, and clean them if present
	Clean drum and rear channels
	Change the speed until the best result
	Change the stretching level thanks to volante
	Confirm dough is really suitable for this machine by considering hydration rate, yeast, resting time according to the specs.
Noise	If any noise is heard from the cone or the channel, adjust the gap between the channel and the cone using the bolts. Try to hear the source of the noise from the motor or conveyor . Check the PLC if there is any error code
Flour Duster NO FLOUR	Check the flour bin if it's empty or not. Clean the flour bin holes and brush inside (if the roller rotates)
	Check the flour duster motor if it's working

In case of any issues, it is recommended to consult your supplier.

General Rules

	Our company is not responsible for any damage caused by unauthorized persons interfering with the machine.
	The machine has been manufactured in accordance with the food product regulations in effect at the time of shipment by the manufacturer. If there are signs of misuse, all parts (dough, soil, water, etc.) of the machine must be replaced immediately.
	The manufacturer is not responsible for wear or fraying caused by improper or insufficient cleaning of the machine.
	Cleaning should be carried out after ensuring the machine is secured.
	Do not use compressed air to clean the internal electronic components. Use vacuum devices instead.
	The instructions in this section apply only if the country code is displayed on the device. If the country code is not visible on the device, refer to the technical instructions that provide the necessary steps to adapt the device to the current conditions of the country.
	Do not tamper with the machine or deactivate its safety systems
	Do not damage or dismantle the safety warnings on top of the machine. If any warnings are damaged, please contact our company immediately to request a replacement.
	Keep the machine clean
	Use your appropriate personal protective equipment for the procedures.
	Check the monthly and daily clean and maintenance
	In case of any issues, we recommend contacting the supplier directly.

Warranty

This warranty applies to all components of your machine, including electronic parts, excluding consumables.

The warranty becomes effective from the date of installation of the equipment.

The seller guarantees that, at the time of shipment, the equipment is in perfect working and aesthetic condition.

The seller provides a 24-month warranty for the supplied equipment under normal operating conditions and in accordance with the product's technical specifications, starting from the invoice date.

During the warranty period, the seller commits, at their discretion, to repair or replace any defective parts but does not cover the removal of the equipment.

The buyer must immediately report any incorrect deliveries or defects in the goods and submit their claims via fax, email, or certified mail, accompanied by appropriate documentation to substantiate the claim. If no claim is made within 7 days of receiving the goods, the seller will consider the delivery approved by the buyer.

In the event of delayed or non-payment, even if only part of the payment is overdue, all warranty rights will be suspended until the outstanding payment is made. The original warranty expiration date remains unchanged.

Warranty Limitations and Exclusions

The warranty does not cover parts subject to normal wear and tear, damage to paintwork, damage occurring during transportation, damages caused by incorrect assembly and/or installation, handling by the buyer or third parties, and goods without the seller's brand.

Except for proven hidden defects, none of the electrical components, motors, or electronic parts are covered by the warranty.

Consumable materials such as:

Belts -Motors - Cones - Plastics

All USED machines are not covered by the warranty.

The warranty will be void if the equipment is used incorrectly, for example, for applications other than those it was designed for, or if it is used "abnormally" and under prolonged stress (a "normal" use refers to intermittent use during a standard work shift). Any tampering with the equipment will void the warranty.

It is mandatory that all parts deemed defective be returned to the seller for replacement. Shipping costs for the return of defective parts and the delivery of replacement parts covered by the warranty are the responsibility of the buyer.

The seller will not reimburse any costs incurred by the buyer for replacing defective parts, nor any indirect damages caused by breakdowns or malfunctioning of the equipment.

Shipping costs for spare parts, defective parts, VAT, and customs fees are the responsibility of the buyers

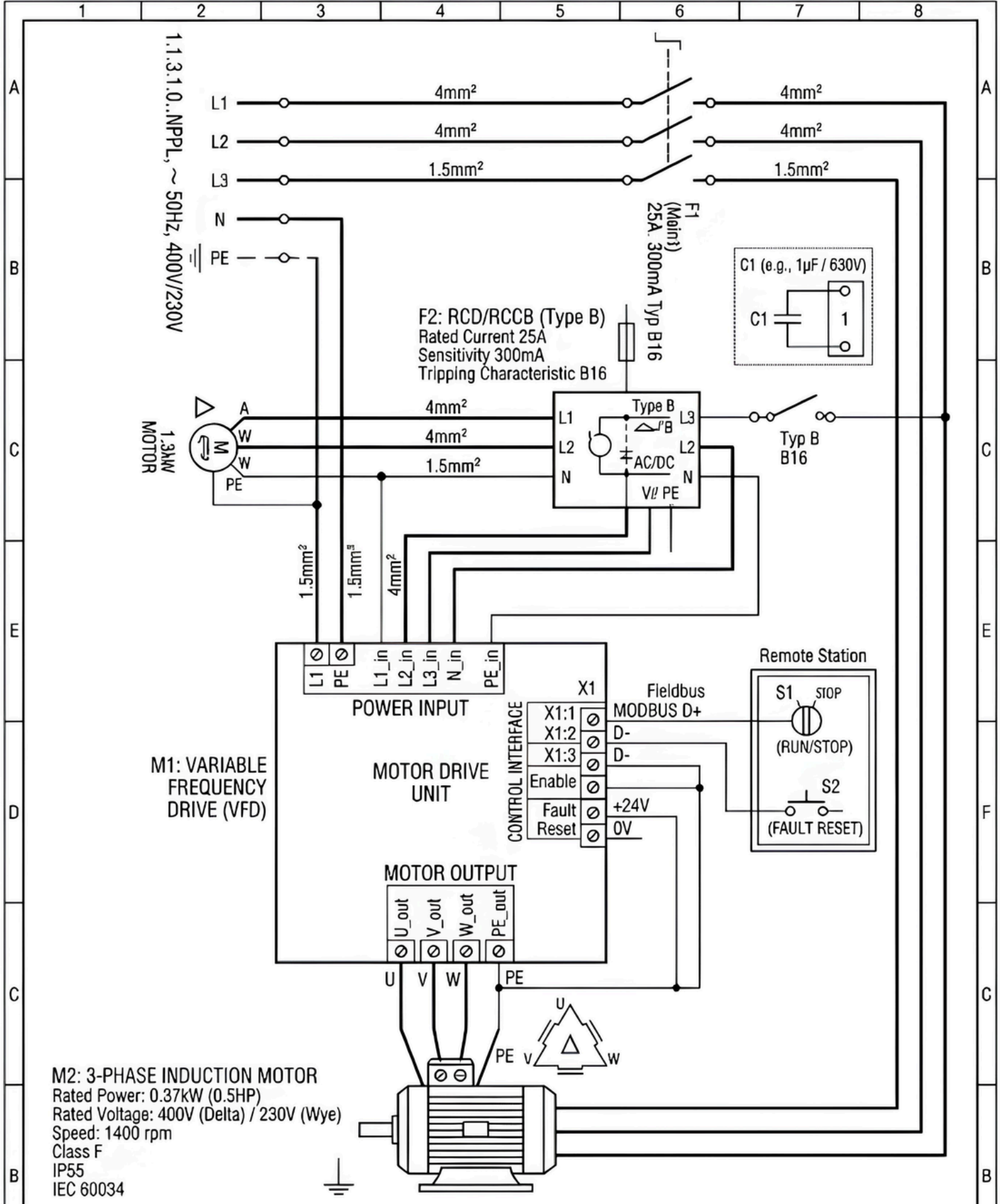

1.1.3.1.0..NPPL, ~ 50Hz, 400V/230V

1.3kW MOTOR

M1: VARIABLE FREQUENCY DRIVE (VFD)

M2: 3-PHASE INDUCTION MOTOR
 Rated Power: 0.37kW (0.5HP)
 Rated Voltage: 400V (Delta) / 230V (Wye)
 Speed: 1400 rpm
 Class F
 IP55
 IEC 60034

 <small>Hatır İşleme Ekipmanları Ve Parçaları Bakery Equipment & Parts</small>		TYM 2000 E.DATA	
NOTES: 1. ALL WIRES ACCORDING TO IEC STANDARDS. 2. USE APPROPRIATE WIRE GAUGE FOR POWER LINES. 3. USE APPROPRIATE WIRE GAUGE FOR POWER LINES.		TITLE	
DRAWN BY A. ENGINEER	FRGET	DRAWING NO. GES-MTR-001 Rev.0	Rev.0
CHECKED BY T. LEAD	CHECKED BY T. LEAD	DATE 2024-05-20	SCALE N/A
		PAGE Page 1 / 1	



UYGUNLUK ONAYI ATTESTATION OF CONFORMITY

Sertifika Numarası / Certificate Number : AVA-CE/011157.06.2021

Üretici / Manufacturer	: ÖNDERMAK ENDÜSTRİYEL MAKİNA OTOMASYON SAN. VE TİC. LTD. ŞTİ.
Üretici Adresi / Manufacturer Address	: ESKİŞEHİR OSB 8. CAD. NO:11 26110 ODUNPAZARI / ESKİŞEHİR / TÜRKİYE
Ürün Tanımı / Product Description	: HAMUR YUVARLAMA MAKİNESİ / DOUGH ROUNDER MACHINE
Tip/Model / Type/Model	: KYM SERIES, TYM SERIES, ROTOMAT SERIES, ROTO-M SERIES
Ticari Marka / Trade Mark	: ÖNDERMAK
İlgili Yönetmelikler / Related Directives	: MAKİNE EMNİYETİ YÖNETMELİĞİ 2006/42/AT Ek VIII MACHINE SAFETY DIRECTIVE 2006/42/EC Annex VIII ALÇAK GERİLİM YÖNETMELİĞİ 2014/35/AB LOW VOLTAGE DIRECTIVE 2014/35/EU
İlgili Standartlar / Related Standards	: TS EN 60204-1:2018, EN 12100:2010
Test Raporu / Test Report	: AVA.LVD/21.00225

AVACERT adı ve adresi yukarıda belirtilen firmanın sunduğu teknik dokümanları inceleyerek, belirlenen ürünün Makina Emniyeti Yönetmeliği 2006/42/AT Ek VIII ve Alçak Gerilim Yönetmeliği 2014/35/AB kurallarına uygunluğunu onaylar. Yukarıda belirtilen tiplerdeki ürün üzerine CE işaretini, üreticinin kendi sorumluluğunda hazırlayacağı AT Uygunluk Beyanı ile iliştirebilir. İncelemesi yapılan ürüne ait olan bu belge tasarımın değişmesi halinde geçerliliğini yitirecektir. Bu belgenin geçerliliğini www.avacert.com internet sayfasından kontrol edebilirsiniz. Bu belge sadece yukarıda adı geçen ürün tip/modelleri için geçerlidir. Yukarıda adı geçen firma ve AVACERT bu belgelerin bir kopyasını tescil tarihinden itibaren 15 yıl süreyle muhafaza etmelidir. Bu belgenin mülkiyet hakkı AVACERT'e aittir ve istenildiğinde iade edilmelidir.

AVACERT examines the technical documents submitted by the company whose name and address are specified above and approves the conformity of the specified product to the Machinery Safety Regulation 2006/42 / EC Annex VIII and Low Voltage Directive 2014/35/EU It may attach the CE mark on the product of the above types with the EC Declaration of Conformity, which the manufacturer will prepare at his own risk. This document, which belongs to the product being examined, will expire if the design changes. You can check the validity of this document on the website www.avacert.com. This document is valid only for the product types / models mentioned above. The above mentioned firm and AVACERT must keep a copy of these documents for 15 years from the date of registration. The ownership of this document belongs to AVACERT and must be returned upon request.

Yayın Tarihi / Issue Date : 21.06.2021
Geçerlilik Tarihi / Validity Date : 20.06.2025



Avacert International Certification Body

Avacert Anadolu Uluslararası Belgelendirme Denetim Teknik Kontrol Eğitim ve Test Hizmetleri LTD. ŞTİ.

Beşevler Mah. Kocayunus Sk. Arslan Plaza K:2 Nilüfer / BURSA

Tel: +90 224 249 43 13 Faks: +90 224 249 41 13 www.avacert.com e-posta: info@avacert.com

DECLARATION OF CONFORMITY

UYGUNLUK BEYANI

OWNER OF DECLARATION: (DEKLARASYON SAHİBİ)	ÖNDERMAK ENDÜSTRİYEL MAKİNA OTOMASYON SANAYİ LİMİTED ŞİRKETİ
ADDRESS: (ADRES)	EOSB 8. CAD. NO:11 26110 ODUNPAZARI/ ESKİŞEHİR - TÜRKİYE
PRODUCT: (ÜRÜN)	DOUGH ROUNDER MACHINE (HAMUR YUVARLAM MAKİNESİ)
TRADEMARK: (MARKA)	ÖNDERMAK
TYPE/MODEL: (TİP/MODEL)	KYM SERIES , TYM SERIES , KYM-VBELT SERIES,KYM PRO SERIES
BASE OF ATTESTATION: (ONAY DAYANAĞI)	FILE OF TECHNICAL DOCUMENTATION, TESTREPORT, OPERATING MANUAL (TEKNİK DOSYA, TEST RAPORU, KULLANMA KILAVUZU)
APPLIED EC DIRECTIVES: (UYGULANAN A.T.YÖNETMELİKLERİ)	LOW VOLTAGE DIRECTIVE (LVD) 2006/95/EC MACHINERY DIRECTIVE 2006/42/EC
APPLIED STANDARDS: (UYGULANAN STANDARTLAR)	EN ISO 12100-2010,TS EN 60204-1
LAST TWO DIGIT YEAR OF: SON 2 BASAMAKLI YIL	CE MARK AFFIXED 17 CE İŞARETİ VURULMUŞTUR 17

We "ÖNDERMAK ENDÜSTRİYEL MAKİNA OTOMASYON SANAYİ VE TİCARET LİMİTED ŞİRKETİ" hereby declare that specified above conforms covering European Parliament and Council Directives (2006/42/EC) of 17 May 2006 Machinery Safety Directive, (2006/95/EC) of 12 December 2006 Low Voltage Directive

Biz "ÖNDERMAK ENDÜSTRİYEL MAKİNA OTOMASYON SANAYİ VE TİCARET LİMİTED ŞİRKETİ" olarak yukarıda belirtilen ürünümüzü Avrupa Topluluğu Yönetmelikleri 17 Mayıs 2006 tarihli (2006/42/EC) Makina Emniyeti Yönetmeliği, 12 Aralık 2006 Tarihli (2006/95/AT) Alçak Gerilim Yönetmeliğine göre uygun olduğunu beyan ederiz.

SIGNATURE :

ÖNDERMAK ENDÜSTRİYEL MAKİNA
OTOMASYON SAN. TİC. LTD. ŞTİ.
Eskişehir OSB 8. Cadde No: 11 ESKİŞEHİR
Eskişehir Y.D. 6570322974

Eskişehir, Turkey
Date: 2026-05-15

Notes

Purchase Date:.....

Serie Number.....

Name of Supplier :.....

ONDERMAK Industrial Bakery Automations and Ovens

Eskişehir OSB 8. Cad. No:11 26110 Eskişehir /Türkiye

Pbx. | + 90 222 236 08 02

Whatsapp | + 90 532 722 02 78

Mail | bilgi@ondermak.com.tr

Web | www.ondermak.com.tr