



V-BELT SERIES

V-Belt Rounders

Boleadora V-Banda

Bantlı Yuvarlama

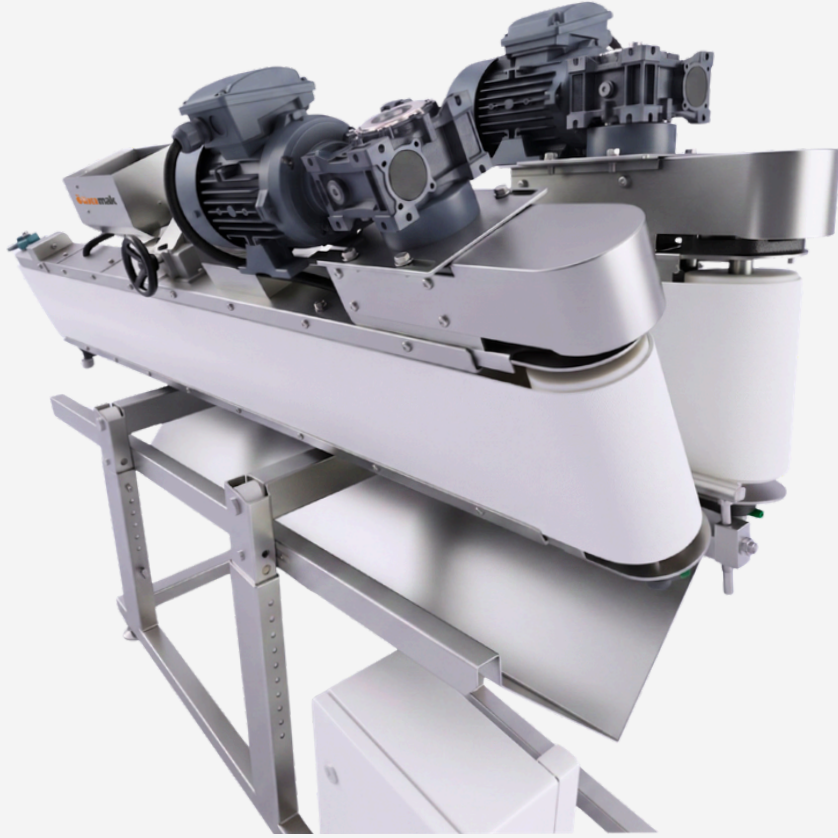

V - Bouleuse De Pâte
Arrotondatrice Per Impasto - V
Округлитель Теста
آلة تدوير العجين.



60 - 85 %
Hydrated
Dough



Max. 2200
pcs/hour

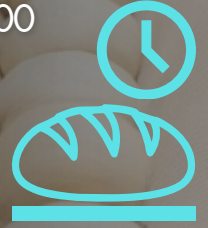

50 - 2000 gram
1.76 oz ≈ 4.41 lb



Speed Control
Inverter



KYM V-SERIES BELT ROUNDERS

Models | Modelos | Modeller | Modèles | Modelli | Модели | الخصائص

V-Belt CLASIC



KYM V1500 - KYM V1700
KYM V1900

V-Belt DESKTOP



V Mini 1400 - V Mini 1500

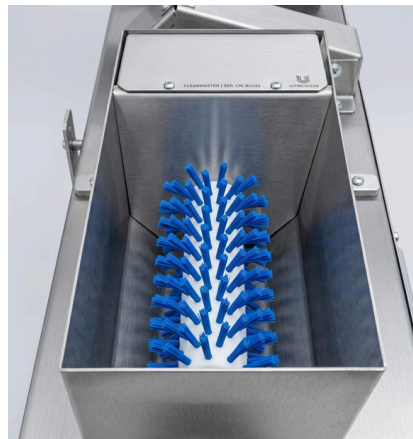

V-Belt Mini
DESKTOP



V-Belt Mini
DESKTOP



With Stand



KYM V-SERIES BELT ROUNDERS

Highlights | Característicos | Özellikler | Caractéristiques | Caratteristiche | Характеристики | الخصائص

EN

- Hydration: 60–85 liters of water per 100 kg of flour
- Speed control inverter for belt
- Adjustable angle between the two belts
- Integrated flourshifter
- Flour collection tray
- Structure made of stainless steel (INOX)
- Belts made of polyester canvas
- Adjustable height feet
- Electromechanical control system
- Optional V-Mini speed control
- Optional V-Mini wheeled support

ES

- Apta entre 60 y 85 litros de agua per 100 kg de harina
- Variador de velocidad para ajuste de las bandas
- Ángulo regulable entre las dos bandas
- Harinador integrado
- Bandeja de recogida de harina
- Estructura fabricada en acero inoxidable (INOX)
- Bandas de lona en poliéster tipo canvas
- Pies con altura regulable
- Control electromecánico
- Control de velocidad opcional V-Mini
- Soporte con ruedas opcional V-Mini

FR

- Adapté de 60 à 85 litres d'eau pour 100 kg de farine
- Contrôle de vitesse des bandes
- Distance réglable entre les bandes
- Système de tamisage de la farine
- Bac de récupération de la farine
- Structure en acier inoxydable (INOX)
- Bandes transporteuses en polyester
- Pieds à hauteur réglable
- Système de commande électromécanique
- Contrôle de vitesse V-Mini en option
- Support mobile V-Mini (avec roues) en option

RU

- Подходит для 60–85 литров воды на 100 кг муки
- Регулировка скорости конвейерных лент
- Регулируемое расстояние между лентами
- Система просеивания муки
- Лоток для сбора муки
- Конструкция из нержавеющей стали
- Конвейерные ленты из полиэстера
- Регулируемые по высоте опоры
- Электромеханическая система управления
- Опциональный регулятор скорости V-Mini
- Опциональная мобильная подставка V-Mini (с колесами)

TR

- 100 kg un için 60–85 litre su aralığına uygun
- Bantlar için hız kontrolü
- Ayarlanabilir bant mesafesi
- Un eleği
- Un toplama tepsi
- Paslanmaz çelik gövde
- Polyester konveyör bant
- Ayarlanabilir yükseklikli ayaklar
- Elektromekanik kontrol sistemi
- Opsiyonel V-Mini hız kontrolü
- Opsiyonel V-Mini mobil stand

IT

- Adatto di 60–85 litri d'acqua per 100 kg di farina
- Controllo della velocità dei nastri
- Distanza regolabile tra i nastri
- Sistema di setacciatura della farina
- Vaschetta di raccolta della farina
- Struttura in acciaio inox
- Nastri trasportatori in poliestere
- Piedini regolabili in altezza
- Sistema di controllo elettromeccanico
- Controllo velocità V-Mini opzionale
- Supporto mobile V-Mini (con ruote) opzionale

AR

- تحكم في سرعة السيور
- مناسب لترطيب 60–85 لتر ماء لكل 100 كغ دقيق
- مسافة قابلة للتعديل بين السيور
- منخل دقيق مدمج
- درج لتجميع الدقيق
- هيكل من الستانلس ستيل
- سيور من البوليستر
- أرجل قابلة لتعديل الارتفاع
- تحكم كهروميكانيكي
- (اختياري) تحكم سرعة V-Mini
- (اختياري) قاعدة متحركة V-Mini



KYM V-SERIES BELT ROUNDERS

Technical Data | Datos Técnicos | Teknik | Techniques | Tecnici | Технические данные | البيانات التقنية

Model Modelo Modèle Modello Модель الموديل	Unit	V-1400 Mini	V-1500 Mini	V-Belt 1500	V-Belt 1700	V-Belt 1900
Capacity Capacidad Kapasite Capacité Capacità Производительность السعة	Adet/sa. - Pcs/hr.	1500	1500	2200	2200	2200
Dough Range Rango de Peso Hamur Gramaj Aralığı Plage de Poids Range di peso Диапазон веса теста نطاق وزن العجين	Gram	50-600		50-2000		
	Lbs	(1.76 oz - 1,32)		(1.76 oz - 4,41)		
Width Ancho Genişlik Largeur Larghezza Ширина العرض (W)	mm	500				
	Inch	19,69 "				
Length Largo Uzunluk Longueur Lunghezza Длина الطول (L)	mm	1400	1500	1500	1700	1900
	Inch	55,12 "	59,06 "	59,06 "	66,93 "	74,8 "
Height Altura Yükseklik Hauteur Altezza Высота الارتفاع (H)	mm	600	600	1200 - 1500		
	Inch	23,62 "	23,62 "	47" - 59"		
Dough Input Entrada Masa Hamur Girişi Entrée Pâte Ingresso pasta Вход теста مدخل العجين (h1)	mm / Inch			700/1000 27,5"- 39,4"		
Dough Output Salida Masa Hamur Çıkışı Sortie Pâte Uscita Impasto Выход теста مخرج العجين (h2)	mm / Inch			750/1100 29,5"- 43,3"		
Power Potencia Güç Puissance Potenza Мощность القدرة	KW	1.1				
Voltage Voltaje Voltaj Tension Tensione Напряжение الجهد الكهربائي	Volt- Vac/Hz	380V 50/60Hz (3Ph/N+PE)				
Weight Peso Neto Ağırlık Poids Peso Вес الوزن	Kg / lbs	150	160	240	260	290
	Lbs	331	353	529	573	639
Speed Control Variador Hız Rölesi + Smart Pan Variateur de Vitesse Controllo velocità Контроль скорости التحكم في السرعة	-	Extra	Extra	✓	✓	✓
Material Material Materyal Matériau Materiale Материал المادة	-	Stainless Steel / INOX/ Paslanmaz Çelik / Нержавеющая сталь / الفولاذ المقاوم للصدأ				



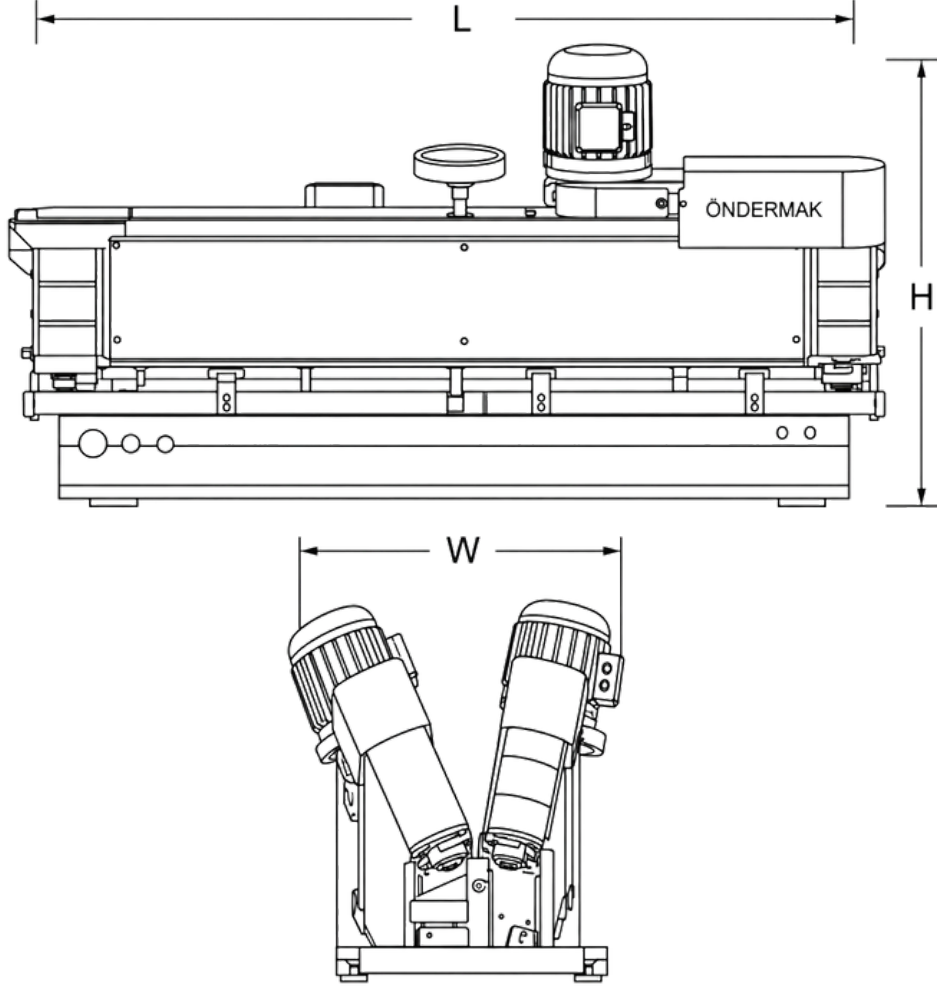

Parameter	mm	Inch
W	500	20
L (V1400)	1400	55
L (V1500)	1500	59
H	600	24



TOLERANCE	UPDATE	Date
%1,00 +/-	2025	01.01.2020

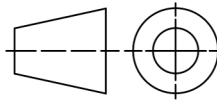

Material	DIN
KG	N/A
Scale:	A4

Model Name :
kym V-BELT MINI

Model Nr. vbelt

notes

CAD

by ondermak - size and dimension scan be changed by producer

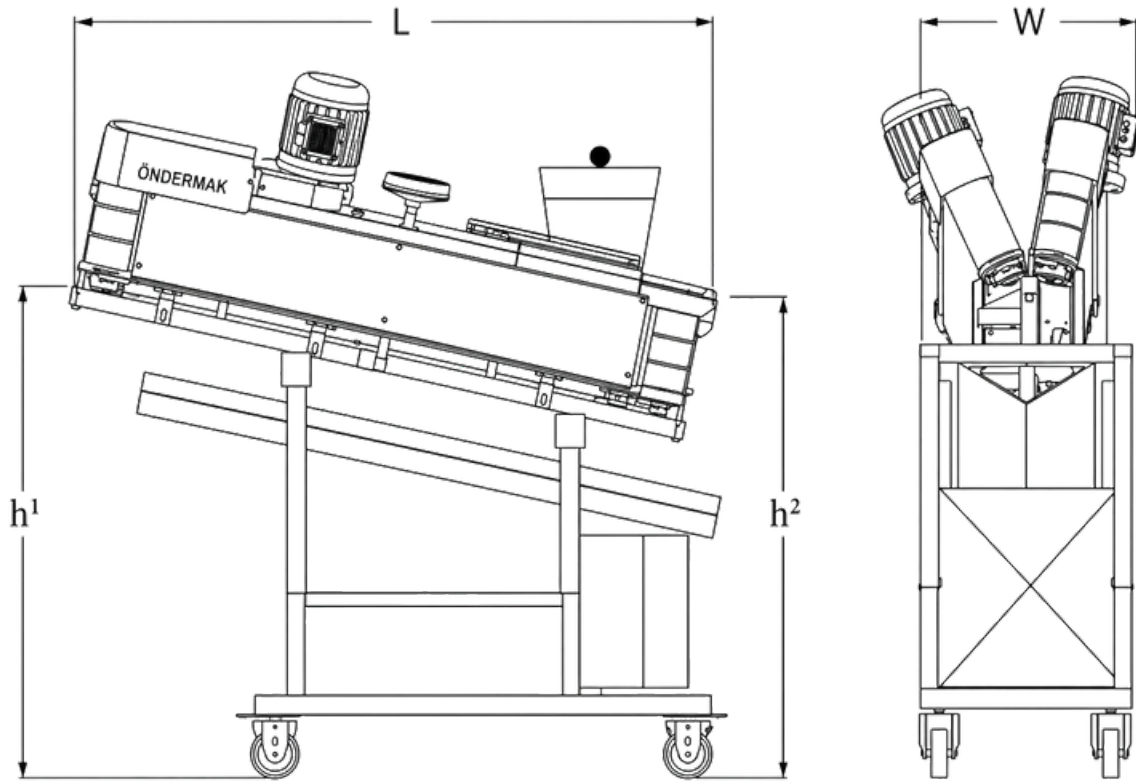

Parameter	mm	Inch
W	500	20
L	1500-1700-1900	59-67-74,8"
H	1200 - 1500	47"- 59"
h1	700-1000	27"- 39"
h2	750-1100	29" - 43"



TOLERANCE	UPDATE	Date
%1,00 +/-	2025	01.01.2020

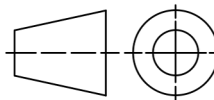

Material	DIN
KG	N/A
Scale:	A4

Model Name :
KYM V BELT

Model Nr. **B BELT**

notes

CAD

by ondermak - size and dimension can be changed by producer



BOOSTED BAKERIES SINCE 1976

50th
ANNIVERSARY



Öndermak Bakery Equipment & Ovens

Eskişehir OSB 8. Cadde No:11 26110 - Eskişehir / Türkiye

Mobile & WhatsApp: +(90) 533 543 07 59

Mail: bilgi@ondermak.com.tr

Pbx: +(90) 222 236 08 03

Fax: +(90) 222 236 08 02

www.undermak.com.tr