



KST 2000 Series

Volumetric Dividers

Divisoras Volumétricas

Volumetrik Kestart



Diviseur Volumétrique
Divisore Volumetrico
Вакуумный делитель теста
قطاعة العجين الحجمية



Min.60 %
Max.85 %
Hydrated
Dough



1000 - 2400
pcs/hour



30 - 1000 gram
1.0 ≈ 2.6 oz



Speed Control



KST 2000 VOLUMETRIC DIVIDER

Models | Modelos | Modeller | Modèles | Modelli | Модели | الخصائص

KST 2000 SINGLE PISTON

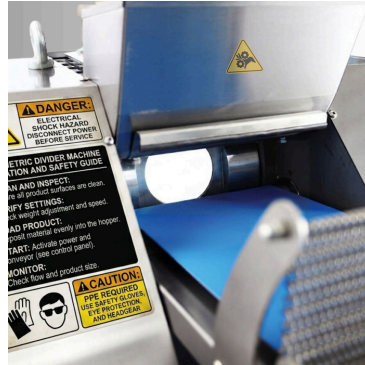

- Piston Ø 70mm | 30/250 gram
- Piston Ø 80mm | 40/350 gram
- Piston Ø 90mm | 70/450 gram
- Piston Ø 100mm | 80/500 gram
- Piston Ø 110mm | 100/600 gram
- Piston Ø 130mm | 200/1000 gram



KST 2000 DOUBLE PISTON



- Piston Ø 70mm | 30/250 gram
- Piston Ø 80mm | 40/350 gram
- Piston Ø 90mm | 70/450 gram
- Piston Ø 100mm | 80/500 gram
- Piston Ø 110mm | 100/600 gram
- Piston Ø 130mm | 200/1000 gram



XL HOPPER
ADD-ON



TEFLON
ADD-ON



TOP COVER
ADD-ON



KST 2000 VOLUMETRIC DIVIDER

Highlights | Característicos | Özellikler | Caractéristiques | Caratteristiche | Характеристики | الخصائص



Suitable for universal dough hydration, weight accuracy $\pm 3\%$ for fresh dough

Adecuado para la hidratación universal, precisión de peso: $\pm 3\%$ para masa fresca

Evrensel hamur hidratasyonu için uygun, gramaj hassasiyeti: $\pm 3\%$ taze hamur için

Convient pour l'hydratation universelle de la pâte, précision du poids: $\pm 3\%$ pour pâte fraîche
Adatto per l'idratazione universale dell'impasto, accuratezza del peso: $\pm 3\%$ per impasto fresco

Подходит для универсальной гидратации теста, Точность веса: $\pm 3\%$ для свежего теста

مناسب لترطيب العجين العالمي، دقة الوزن: $\pm 3\%$ للعجين الطازج



12 mm thick platin body construction with stainless steel drum, panels, and hopper

Estructura de platina de 12 mm, el tambor, los paneles y la tolva de acero inoxidable

12 mm platin şase, tambur, paneller ve hazne paslanmaz çelikten imal edilmiştir

Structure en platine de 12 mm, tambour, panneaux et trémie en acier inoxydable

Struttura in platino da 12 mm, tamburo, pannelli e tramoggia in acciaio inox

Полностью нержавеющая Платиновая конструкция толщиной 12 мм с барабаном, панелями и бункером из нержавеющей стали

هيكل بلاتين بسماكة 12 مم مع أسطوانة ولوحات وقمع من الفولاذ المقاوم للصدأ



Double lubrication pump for precise and stable suction performance

Doble bombas de lubricación para alto rendimiento de succión

Çift yağlama pompası ile yüksek vakumlama performansı sunar

2 pompes de lubrification pour haute performance d'aspiration

2 pompe di lubrificazione per alte prestazioni di aspirazione

2 смазочных насоса для высокой всасывающей производительности

مضختنا تشحيم لأداء شفت عالي



Closed-circuit lubricating system equipped with two oil tanks

Sistema de lubricación de circuito cerrado equipado con dos depósitos de aceite

2'li yağlama tankı, kapalı devre yağlama sistemi

Système de lubrification en circuit fermé équipé de deux réservoirs d'huile

Sistema di lubrificazione a circuito chiuso dotato di due serbatoi d'olio

Система смазки с замкнутым контуром, оснащённая двумя масляными баками

نظام تشحيم مغلق مزود بخزانين للزيت



Easy oil filling thanks to external oil filling tap

Llenado de aceite fácil gracias a grifo de llenado externo

Kolay yağ doldurma, harici yağ doldurma tapası sayesinde

Remplissage d'huile facile grâce au robinet de remplissage externe

Riempimento dell'olio facile grazie al rubinetto di riempimento esterno

Лёгкая заправка масла благодаря внешнему маслозаливному крану

تعبئة زيت سهلة بفضل صنوبر تعبئة خارجي



KST 2000 VOLUMETRIC DIVIDER

Highlights | Característicos | Özellikler | Caractéristiques | Caratteristiche | Характеристики | الخصائص



External flour stiffer

Harinadora externa
Unlama ünitesi

Saupoudreuse de farine externe
Spolveratore di farina esterno
Внешний мукопросypатель
منثر دقيق خارجي



Oil level window

Ventana nivel de aceite
Yağ göstergesi

Fenêtre de niveau d'huile
Finestra livello olio
Окно уровня масла
نافذة مستوى الزيت



Finely height-adjustable conveyor belt with belt-cleaning scraper

Cinta transportadora de altura ajustable con rascador de limpieza de lona
Yükseklik ayarlı , bant temizleme aparatlı konveyör tertibat

Convoyeur à bande réglable en hauteur finement avec grattoir de nettoyage de bande
Nastro trasportatore regolabile in altezza con raschiatore di pulizia della cinghia
Тонко регулируемый по высоте конвейерный ремень с очистным скребком
حزام ناقل قابل لتعديل الارتفاع بدقة مع مكشطة تنظيف الحزام



Weight Control - Control Peso - Ağırlık Kontrolü - Contrôle Poids - Controllo Peso - Контроль веса - مراقبة الوزن



Analogue
Dial Handwheel



Setting
Dial Handwheel



Digital Control



Electromechanical control with variable-speed inverter, error and safety alarms

Control electromecánico con varidor de velocidad alarmas de error y seguridad
Elektromekanik kontrol hızlı ayarlı invertör, hata ve güvenlik alarmları

Commande électromécanique avec variateur de vitesse, alarmes d'erreur et de sécurité e
Controllo elettromeccanico con inverter a velocità variabile, allarmi di errore e sicurezza
Электромеханическое управление с преобразователем переменной скорости, сигналами ошибок и безопасности

تحكم كهروميكانيكي مع محول سرعة متغير، إنذارات خطأ وسلامة



KST 2000 VOLUMETRIC DIVIDER

Highlights | Característicos | Özellikler | Caractéristiques | Caratteristiche | Характеристики | الخصائص



Optional XL hopper for increased dough capacity of up to 120 liters (256 lb)

Tolva XL opcional para aumentar la capacidad de masa hasta 120 litros

Opsiyonel XL huni ile 120 litrelik hamur kapasitesi

Trémie xl optionnelle pour augmenter la capacité de pâte jusqu'à 120 litres

Tramoggia xl opzionale per aumentare la capacità di impasto fino a 120 litri

Дополнительный xl бункер для увеличенной вместимости теста до 120 литров

اختياري لزيادة سعة العجين حتى 120 لترًا



Stainless steel hopper top cover with safety photocell

Rejilla superior de tolva de INOX con fotocélula de seguridad

Paslanmaz malzemeden imal edilmiş, güvenlik switchli huni üst koruma kapağı

Couvercle supérieur de trémie en INOX avec cellule photoélectrique de sécurité

Coperchio superiore tramoggia in acciaio INOX con fotocellula di sicurezza

Верхняя крышка бункера из нержавеющей стали с предохранительным фотоэлементом

غطاء علوي للقمع من الفولاذ المقاوم للصدأ مزود بخلايا ضوئية أمان

Teflon-coated hopper for the non-stick suction performance

Tolva teflonada para un rendimiento de succión antiadherente

Teflon kaplı huni ile hamuru tam gramajda çeker

Trémie revêtue de téflon pour une performance d'aspiration antiadhésive

Tramoggia rivestita in teflon per prestazioni di aspirazione antiaderenti

Бункер с тефлоновым покрытием для антилипкой всасывающей производительности

قمع مطلي بالتفلون لأداء شفط غير لاصق



Digital dough weight adjustment and piece counter

Ajuste digital de peso de masa y contador de piezas

Dijital hamur ağırlığı ayarı ve hamur sayacı

Réglage numérique du poids de pâte et compteur de pièces

Réglage numérique du poids de pâte et compteur de pièces

Цифровая регулировка веса теста и счётчик изделий

تعديل وزن العجين رقميًا وعدّاد القطع



380-400 VAC
50/60 Hz
3-NPE



2 años de garantía
2 yıl garanti
2 ans de garantie
2 anni di garanzia
2 года гарантии
سنتان ضمان



KST 2000 VOLUMETRIC DIVIDER

Technical Data | Datos Técnicos | Teknik | Techniques | Tecnici | Технические данные | البيانات التقنية

Model - Modelo	Unit	KST 2000 Single Piston	KST 2000 Double Piston
Capacity / Capacidad / Kapasite / Capacité / Capacità / Производительность / السعة	Ad/pcs	2400	3600
Dough Range / Rango de Peso / Hamur Gramaj Aralığı / Plage de Poids / Range di peso / Диапазон веса теста / نطاق وزن العجين	gram	Piston Ø 70mm 30/250 gram Piston Ø 80mm 40/350 gram Piston Ø 90mm 70/450 gram Piston Ø 100mm 80/500 gram Piston Ø 110mm 100/600 gram Piston Ø 130mm 200/1000 gram	
	oz/lb	Piston Ø 2.75" 1-9 oz Piston Ø 3.15" 1-12 oz Piston Ø 3.55" 2-16 oz Piston Ø 3.95" 3-18 oz Piston Ø 4.35" 4-21 oz Piston Ø 5.15" 7-35 oz	
Width / Ancho / Genişlik / Largeur / Larghezza / Ширина / العرض (W)	mm	700	900
	(inch)	28	35
Length / Largo / Uzunluk (L) / Longueur / Lunghezza / Длина / الطول (L)	mm	1450	1450
	(inch)	57	57
Height / Altura / Yükseklik (H) / Hauteur / Altezza / Высота / الارتفاع (H)	mm	1720	1720
	(inch)	68	68
Power / Potencia / Güç / Puissance / Potenza / Мощность / القدرة	V/hz	380V 50/60Hz (3Ph/N+PE)	
Hopper capacity/ Capacidad de la tolva Hazne kapasitesi/ Capacità de la trémie Capacità della tramoggia/ Ёмкость бункера سعة القمع	Liter	70	90
Voltage / Voltaje / Voltaj / Tension / Tensione / Напряжение / الجهد الكهربائي	KW	1.1	1.5
Weight / Peso Neto / Ağırlık / Poids / Peso / Вес / الوزن	KG	450	600
	(lb)	992	1323
Material / Materyal / Matériau / Materiale / Материал / المادة	-	Stainless Steel / INOX/ Paslanmaz Çelik / Нержавеющая сталь / الفولاذ المقاوم للصدأ	



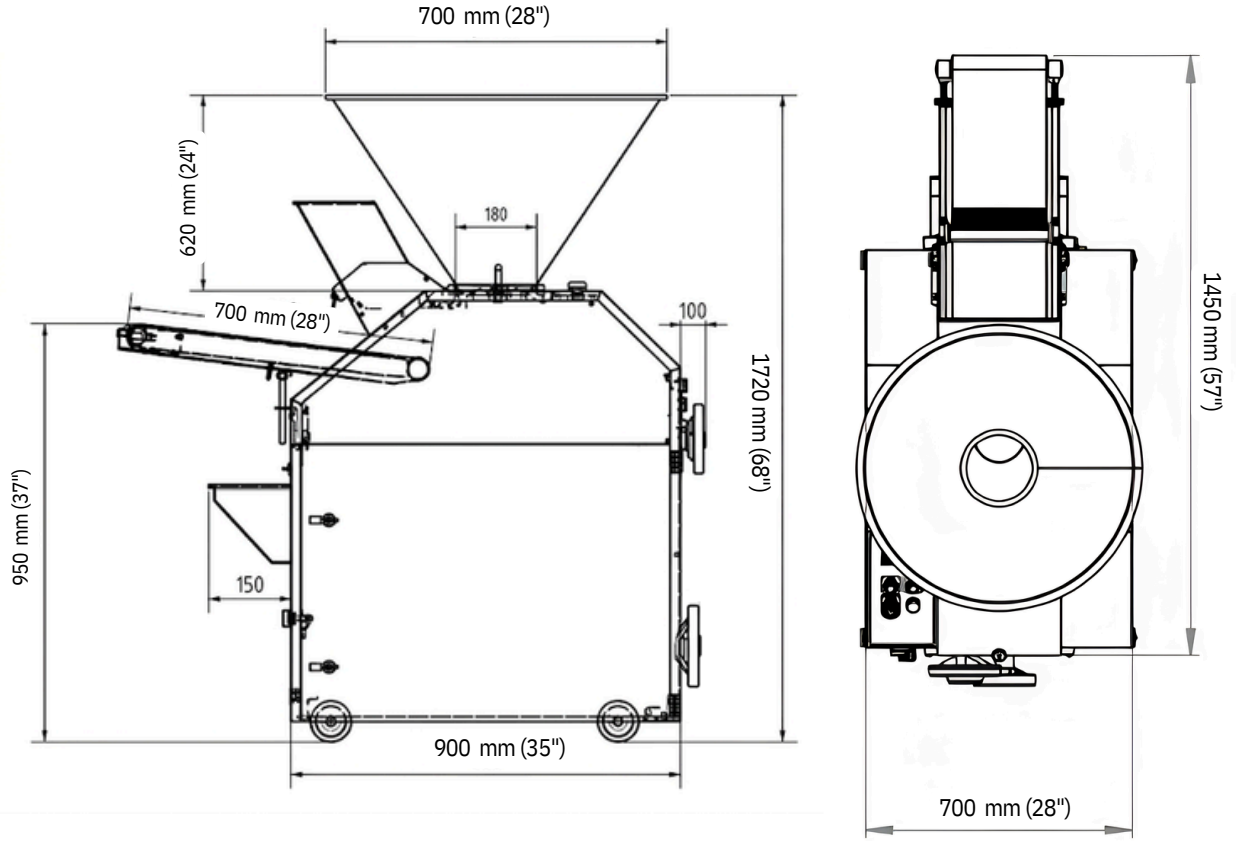

Parameter	mm	Inch
W	700	28
L	1450	57
H	1720	68
d	700	28
c	620	24
e	700	28
f	950	37



TOLERANCE	UPDATE	Date
%1,00 +/-	2025	01.01.202

notes

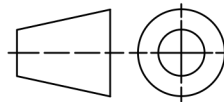

Material	DIN
KG	N/
Scale:	A A4

Model Name :
KST 2000 SINGLE

Model Nr. **KST SERIES**

CAD by ondermak - size and dimension scan can be changed by producer

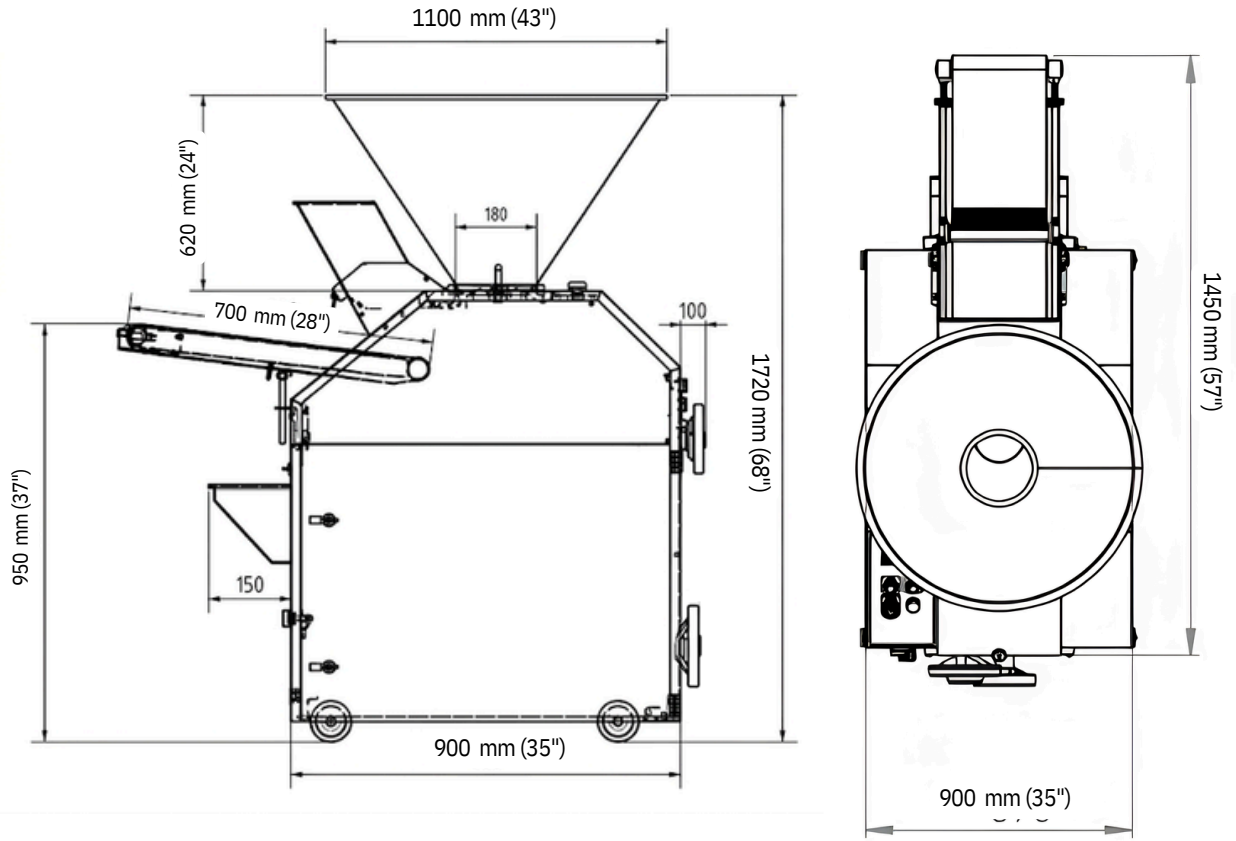

Parameter	mm	Inch
W	900	35
L	1450	57
H	1720	68
d	1100	43
c	620	24
e	700	28
f	950	37



TOLERANCE	UPDATE	Date
%1,00 +/-	2025	01.01.202

notes

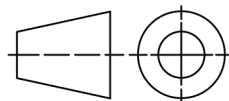

Material	DIN
KG	N/
Scale:	A A4

Model Name :
KST 2000 DOUBLE

Model Nr. **KST SERIES**

CAD by ondermak - size and dimension scan can be changed by producer



BOOSTED BAKERIES SINCE 1976

50th
ANNIVERSARY



Öndermak Bakery Equipment & Ovens

Eskişehir OSB 8. Cadde No:11 26110 - Eskişehir / Türkiye

Mobile & WhatsApp: +(90) 533 543 07 59

Mail: bilgi@ondermak.com.tr

Pbx: +(90) 222 236 08 03

Fax: +(90) 222 236 08 02

www.undermak.com.tr