



# TYM 2000

## Eccentric Rounder

Boleadora Excéntrica

Eksantrik Yuvarlama Makinesi

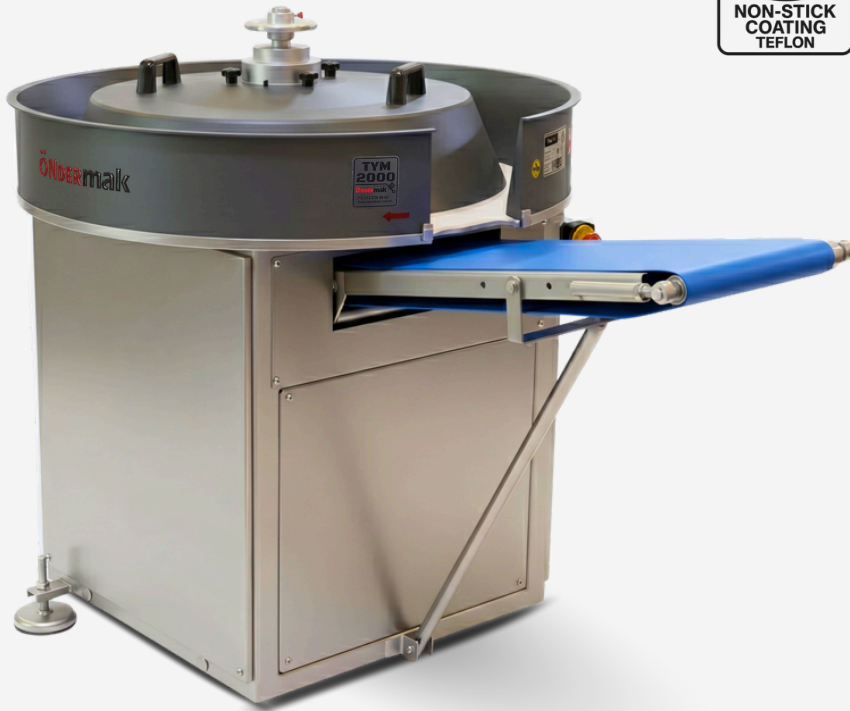

Max. 85 %  
Hydrated  
Dough



Max. 2000  
pcs/hour



50 gram - 4000 kg  
1.76 oz ≈ 8.8 lb



Speed Control



**Arrondisseuse Excentrique**  
**Arrotondatrice Eccentrica**  
Эксцентрикый Округлители теста  
مدور غريب الأطوار



# TYM ECCENTRIC ROUNDER

Models | Modelos | Modeller | Modèles | Modelli | Модели | الخصائص

## TYM - Flour Sifter ADD-ON



## TYM - INOX Cover ADD-ON

## TYM - Oiling Unit ADD-ON



# TYM ECCENTRIC ROUNDER

Highlights | Característicos | Özellikler | Caractéristiques | Caratteristiche | Характеристики | الخصائص



## Suitable for universal dough hydration

Adecuado para la hidratación universal de la masa  
Evrensel hamur hidratasyonu için uygun

Convient pour l'hydratation universelle de la pâte  
Adatto per l'idratazione universale dell'impasto  
Подходит для универсальной гидратации теста  
مناسب لترطيب العجين العالمي



- Ciabatta
- Focaccia
- Rustic
- Sourdough
- Artisan
- Country
- Pizza
- Panetone
- Pita



## Completely stainless steel structure, durability

Estructura completamente de acero inoxidable, durabilidad  
Tamamen paslanmaz çelik yapı, dayanıklılık

Structure entièrement en acier inoxydable, durabilité  
Struttura completamente in acciaio inossidabile, durata  
Полностью нержавеющая стальная конструкция, долговечность  
هيكل من الفولاذ المقاوم للصدأ بالكامل، متانة



## Teflon-Coated drum and rear channels for superior rounding

Teflonados cono y canales para superior redondeo

Dahi mükemmel yuvarlama için Teflon tambur ve kanallar

Cône et canaux revêtus de téflon pour un arrondi supérieur  
Cono e canale rivestiti in teflon per un arrotondamento superiore  
Конус и направляющие с тефлоновым покрытием для превосходного округления  
مخروط ومسارات مطلية بالتفلون للحصول على تدوير فائق



## Height-adjustable conveyor belt (80/90/100 cm)

Cinta transportadora ajustable en altura  
Yüksekliği ayarlanabilir konveyör bant

Convoyeur à bande réglable en hauteur  
Nastro trasportatore regolabile in altezza  
Высота регулируемая конвейерная лента  
حزام ناقل قابل لتعديل الارتفاع (80/90/100 سم)



CONTROL  
CONTROL  
CONTROL



## Speed Control Unit Inverter

Variador de velocidad  
Hız ayarlı invertör

Unité de contrôle de vitesse  
Unità di controllo della velocità  
Блок управления скоростью  
وحدة التحكم في السرعة

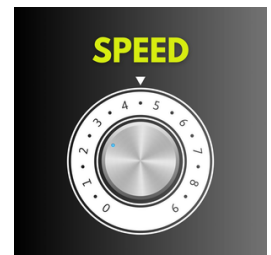

# TYM ECCENTRIC ROUNDER

Highlights | Característicos | Özellikler | Caractéristiques | Caratteristiche | Характеристики | الخصائص



## External adjustable motorized flour sifter

Harinadorda ajustable external  
Ayarlanabilir un eleği

*Tamiseuse de farine réglable*  
*Setaccio per farina regolabile*  
*Регулируемое сито для муки*  
منخل دقيق قابل للتعديل



## Fabric-coated drum and side channels for tough doughs

Cono y canales recubiertos de tela para masas duras  
Kumaş kaplı konik ve çeper sert hamurlara uygun

*Cône et canaux revêtus de tissu pour pâtes fermes*  
*Cono e canali rivestiti in tessuto per impasti duri*  
*Конус и каналы, покрытые тканью, для тугого теста*  
مخروط وقنوات مغطاة بالقماش للعجائن الصلبة



## External oiling system for high-hydration and artisan doughs

Sistema de engrase externo para masas de alta hidratación y artesanas  
Yüksek hidrasyonlu ve geleneksel hamurlar için harici yağlama sistemi

*Système de huilage externe pour pâtes à haute hydratation et artisanales*  
*Sistema di oliatura esterna per impasti ad alta idratazione e artigianali*  
*Внешняя система смазки для теста с высокой гидратацией и ремесленного теста*  
نظام تزييت خارجي للعجائن عالية الترطيب والحرفية

## External Stainless steel top cover with safety switch

Cubierta protectora de INOX con micro  
Paslanmaz üst kapak, güvelik tertibatlı

*Couvercle en acier inoxydable avec interrupteur de sécurité*  
*Coperchio in acciaio inox con interruttore di sicurezza*  
*Крышка из нержавеющей стали с предохранительным выключателем*  
غطاء من الفولاذ المقاوم للصدأ مع مفتاح أمان



380-400 VAC  
50/60 Hz  
3-NPE



2 años de garantía  
2 yıl garanti  
2 ans de garantie  
2 anni di garanzia  
2 года гарантии  
ستنان ضمان



# TYM ECCENTRIC ROUNDER

Technical Data | Datos Técnicos | Teknik | Techniques | Tecnici | Технические данные | البيانات التقنية

Model - Modelo	Unit	TYM 2000		
Capacity / Capacidad / Kapasite / Capacité / Capacità / Производительность / السعة	Ad/pcs	2000		
Dough Range / Rango de Peso / Hamur Gramaj Aralığı / Plage de Poids / Range di peso / Диапазон веса теста / نطاق وزن العجين	gr.	50-4000		
	oz/lb	1.70/8.80 lb		
Width / Ancho / Genişlik / Largeur / Larghezza / Ширина / العرض (W)	mm	1100		
	(inch)	43		
Length / Largo / Uzunluk (L) / Longueur / Lunghezza / Длина / الطول (L)	mm	1850		
	(inch)	73		
Height / Altura / Yükseklik (H) / Hauteur / Altezza / Высота / الارتفاع (H)	mm	1300		
	(inch)	51		
Dough Output / Salida de Masa / Hamur Çıkışı / Sortie de Pâte / Выход Теста / Uscita Pasta / مخرج العجين (h2)	mm	800	900	1000
	(inch)	31	35	39
Dough Input (h1) / Entrada Masa / Hamur Girişi / Entrée Pâte / Ingresso pasta / Вход теста / مدخل العجين (h1)	mm	1050		
	(inch)	41		
Power / Potencia / Güç / Puissance / Potenza / Мощность / القدرة	v/hz	380V 50/60Hz (3Ph/N+PE)		
Voltage / Voltaje / Voltaj / Tension / Tensione / Напряжение / الجهد الكهربائي	KW	0,55 + 0,75		
Weight / Peso Neto / Ağırlık / Poids / Peso / Вес / الوزن	KG	350		
	(lb)	720		
Material / Materyal / Matériau / Materiale / Материал / المادة	-	stainless + forged cast aluminium / INOX + aluminio fundido forjado/Paslanmaz + alüminyum döküm / Inox + aluminium moulé forgé / inox + alluminio fuso forgiato / Нержавеющая сталь + кованный литой алюминий / الفولاذ المقاوم للصدأ + الألمنيوم المصبوب المطروق		



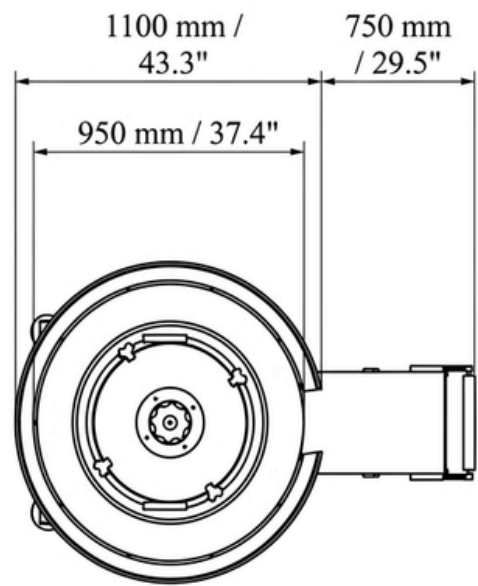
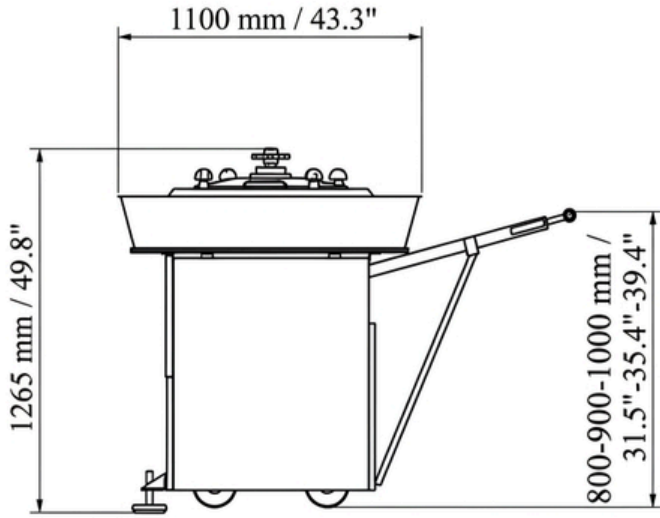

Parameter	mm	Inch
W	1100	43
L	1850	73
H	1265	50
D	1050	41



TOLERANCE	UPDATE	Date
%1,00 +/-	2025	01.01.2020

notes

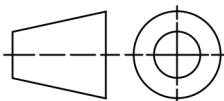

Material	DIN
KG	N/A
Scale:	A4

Model Name :  
**TYM 2000**

Model Nr. **TYM**

CAD by ondermak - size and dimension scan can be changed by producer



BOOSTED BAKERIES SINCE 1976

50<sup>th</sup>  
ANNIVERSARY



## Öndermak Bakery Equipment & Ovens

Eskişehir OSB 8. Cadde No:11 26110 - Eskişehir / Türkiye

Mobile & WhatsApp: +(90) 533 543 07 59

Mail: [bilgi@ondermak.com.tr](mailto:bilgi@ondermak.com.tr)

Pbx: +(90) 222 236 08 03

Fax: +(90) 222 236 08 02

[www.undermak.com.tr](http://www.undermak.com.tr)