



KYM SERIES

Conical Rounders

Boleadora Cónica

Konik Yuvarlama Makinesi



Arrondisseuse Conique

Arrotondatrice Conica

Конусные Округлители теста

آلة تكوير العجين



55 - 85 %
Hydrated
Dough



Max. 6000
pcs/hour

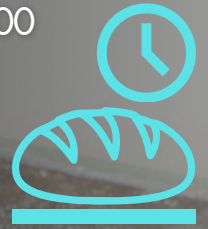

30 - 2000 gram
1.76 oz ≈ 4.41 lb



Cool Air Flow



KYM SERIES CONICAL ROUNDERS

Models | Modelos | Modeller | Modèles | Modelli | Модели | الخصائص

KYM 1600



40 - 120 gr.
1.40 ≈ 4.20 oz



550 cm
216 "



3000 pcs/hr.

KYM 1800



80 - 700 gr.
2.82 oz ≈ 1.54 lb



580 cm
230 "



3000 pcs/hr.

KYM 2000



200 - 800 gr.
7.05 oz ≈ 1.76 lb



380 cm
149 "



3000 pcs/hr.

KYM 4800



50 - 1200 gr.
1.76 oz ≈ 2.64 lb



370 cm
145 "



4800 pcs/hr.

KYM



1000 - 2000 gr.
2.20 ≈ 4.40 lb



460 cm
181 "



2000 pcs/hr.

KYM PRO



50 - 1500 gr.
0.11 oz ≈ 3.30 lb



610 cm
240 "



6500 pcs/hr.



KYM SERIES CONICAL ROUNDERS

Highlights | Característicos | Özellikler | Caractéristiques | Caratteristiche | Характеристики | الخصائص



Suitable for universal dough hydration

Adecuado para la hidratación universal de la masa
Evrensel hamur hidratasyonu için uygun

Convient pour l'hydratation universelle de la pâte
Adatto per l'idratazione universale dell'impasto
Подходит для универсальной гидратации теста
مناسب لترطيب العجين العالمي



Completely stainless steel structure, durability

Estructura completamente de acero inoxidable, durabilidad
Tamamen paslanmaz çelik yapı, dayanıklılık

Structure entièrement en acier inoxydable, durabilité
Struttura completamente in acciaio inossidabile, durata
Полностью нержавеющей стальная конструкция, долговечность
هيكل من الفولاذ المقاوم للصدأ بالكامل، متانة

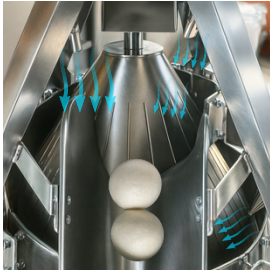

Cool "Air Blowing" system to avoid dough sticking

Sistema de soplado de aire frío para evitar que la masa se pegue
Soğuk hava üfleme sistemi hamurun yapışmasını önlemek için

Système de soufflage d'air froid pour éviter que la pâte colle
Sistema di soffiaggio d'aria fredda per evitare che l'impasto si attacchi
Система подачи холодного воздуха чтобы избежать прилипания теста
نظام نفخ هواء بارد، لتجنب التصاق العجين



Dual-Side flour sifter (Front/Back)

Doble Harinadora delantero y trasero
Ön ve arka un eleği

Farinador avant et arrière
Farinadora anteriore e posteriore
Фронтальное и заднее сито для муки
منخل دقيق أمامي وخلفي



Flour recycling system with under-cone brush and flour bin

Sistema de reciclaje de harina con cepillo bajo el cono y contenedor de harina
Un geri dönüşüm sistemi, koni altı fırça ve un haznesi ile

Système de recyclage de farine avec brosse sous le cône et bac à farine
Sistema di riciclo della farina con spazzola sotto-cono e contenitore della farina
Система переработки муки с щёткой под конусом и бункером для муки
نظام إعادة تدوير الدقيق بفريشة تحت المخروط وصندوق دقيق



KYM SERIES CONICAL ROUNDERS

Highlights | Característicos | Özellikler | Caractéristiques | Caratteristiche | Характеристики | الخصائص



FDA-compliant aluminum tracks and cones

Canales y cono de aluminio conformes a la FDA
Sağlığa uygun helezon ve huni

Rails et cônes en aluminium conformes à la FDA
Binari e cono in alluminio conformi alla FDA
Алюминиевые каналы и конусы, соответствующие требованиям FDA
مسارات وأقماع من الألمنيوم متوافقة مع إدارة الغذاء والدواء

OUR DESIGN
OUR DESIGN
OUR DESIGN

Teflon-Coated cone and tracks for superior rounding

Teflonados cono y pistas para superior redondeo
Dahi mükemmel yuvarlama için Teflon huni ve kanallar

Cône et pistes revêtus de téflon pour un arrondi supérieur
Cono e binari rivestiti in teflon per un arrotondamento superiore
Конус и направляющие с тefлоновым покрытием для превосходного округления
مخروط ومسارات مطلية بالتفلون للحصول على تدوير فائق

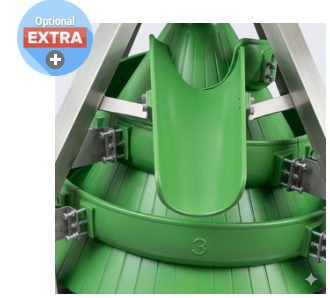

External outfeed conveyor for smooth dough transfer

Cinta transportadora externa de salida para una transferencia suave de la masa
Hamurun düzgün aktarımı için harici çıkış konveyörü

Convoyeur externe de sortie pour un transfert de pâte fluide
Nastro trasportatore esterno di uscita per un trasferimento regolare dell'impasto
Внешний выпускной конвейер для плавной передачи теста
ناقل خارجي للإخراج لنقل العجين بسلاسة

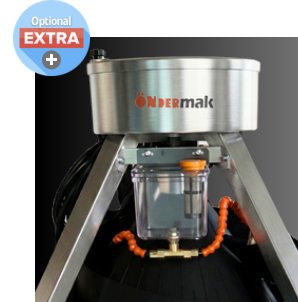

External oiling system for high-hydration and artisan doughs

Sistema de engrase externo para masas de alta hidratación y artesanas
Yüksek hidrasyonlu ve geleneksel hamurlar için harici yağlama sistemi

Système de huilage externe pour pâtes à haute hydratation et artisanales
Sistema di oliatura esterna per impasti ad alta idratazione e artigianali
Внешняя система смазки для теста с высокой гидратацией и ремесленного теста
نظام تزييت خارجي للعجائن عالية الترطيب والحرفية

Hot air blower for surface drying of artisan dough

Soplador de aire caliente para el secado superficial de masas artesanas
Özel tip hamurların yüzey kurutması için sıcak hava üfleiyici

Souffleur d'air chaud pour le séchage de surface des pâtes artisanales
Soffiatore ad aria calda per l'asciugatura superficiale degli impasti artigianali
Воздуходувка горячего воздуха для поверхностной сушки ремесленного теста
منفاخ هواء ساخن لتجفيف سطح العجين الحرفي

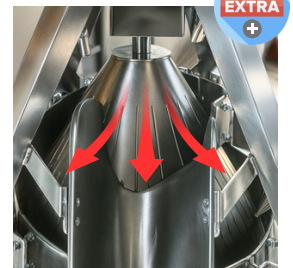

KYM SERIES CONICAL ROUNDERS

Highlights | Característicos | Özellikler | Caractéristiques | Caratteristiche | Характеристики | الخصائص

CONTROL
CONTROL
CONTROL

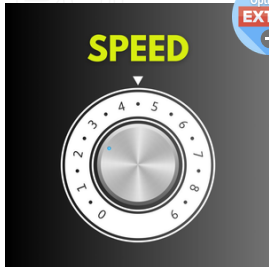

Optional
EXTRA
+

Speed Control Unit Inverter

Variador de velocidad

Hız Ayarı

Unité de contrôle de vitesse

Unità di controllo della velocità

Блок управления скоростью

وحدة التحكم في السرعة



Optional
EXTRA
+

PLC Control 7" Touch



Standard



VERSIONS
VERSIONS
VERSIONS

Oiling



Conveyor

VERSIONS
VERSIONS
VERSIONS



Teflon



380-400 VAC
50/60 Hz
3-NPE

2
YEARS
WARRANTY

2 años de garantía
2 yıl garanti
2 ans de garantie
2 anni di garanzia
2 года гарантии
سنتان ضمان



KYM SERIES CONICAL ROUNDERS

Technical Data | Datos Técnicos | Teknik | Techniques | Tecnici | Технические данные | البيانات التقنية

Model - Modelo	Unit	KYM1600	KYM1800	KYM2000	KYM4800	KYM6000	KYM Pro
Capacity / Capacidad / Kapasite / Capacité / Capacità / Производительность / السعة	Ad/pcs	3000	3000	2000	4800-6000	2000	6500
Dough Range / Rango de Peso / Hamur Gramaj Aralığı / Plage de Poids / Range di peso / Диапазон نطاق وزن العجين / веса теста	gr.	40-120	80-700	200-800	50-1200	1000-2000	50-1500
Tour No. / Track Length N° de Vueltas / Longitud de Pista Tur Sayısı / Kanal Uzunluğu Nb de Tours / Longueur de Piste N. di Giri / Lunghezza Pista Кол-во оборотов / Длина пути المسار / طول اللفات / عدد اللفات	Nr./cm	3 - 549	3 - 549	2 - 380	2 - 370	3 - 460	3 - 610
Width / Ancho / Genişlik / Largeur / العرض / Larghezza / Ширина	(W)mm	1000	1000	1000	1000	1000	1155
Length / Largo / Uzunluk (L) / / Longueur / Lunghezza / Длина الطول	(L)mm	1000	1000	1000	1585	1000	1200
Height / Altura / Yükseklik (H) / الارتفاع / Hauteur / Altezza / Высота	(H)mm	1585	1585	1585	920	920	1835
Dough Input (h1) / Entrada Masa / Hamur Girişi / Entrée Pâte / مدخل / Ingresso pasta / Вход теста العجين	(h1)mm	920	920	920	1050	1050	1190
Dough Output / Salida de Masa / Hamur Çıkışı / Sortie de Pâte / مخرج / Выход Теста / Uscita Pasta (h2) العجين	(h2)mm	1050	1050	1050	1050	1050	1200
Power / Potencia / Güç / Puissance / القدرة / Potenza / Мощность	V/hz	380 V50Hz N+PE 3 Phase					
Voltage / Voltaje / Voltaj / Tension / Tensione / Напряжение / الجهد الكهربائي	KW	1.1	1.1	1.1	1.1	1.1	2.5
Weight / Peso Neto / Ağırlık / Poids / الوزن / Peso / Вес	KG	205	235	205	235	325	410
Material / Materyal / Matériau / Materiale / Материал / المادة	-	stainless + forged cast aluminium/INOX + aluminio fundido forjado Paslanmaz + alüminyum döküm /Inox + aluminium moulé forgé/ inox + alluminio fuso forgiatoНержавеющая сталь + кованный литой алюминий/الفولاذ المقاوم للصدأ + الألمنيوم المصبوب المطروق					



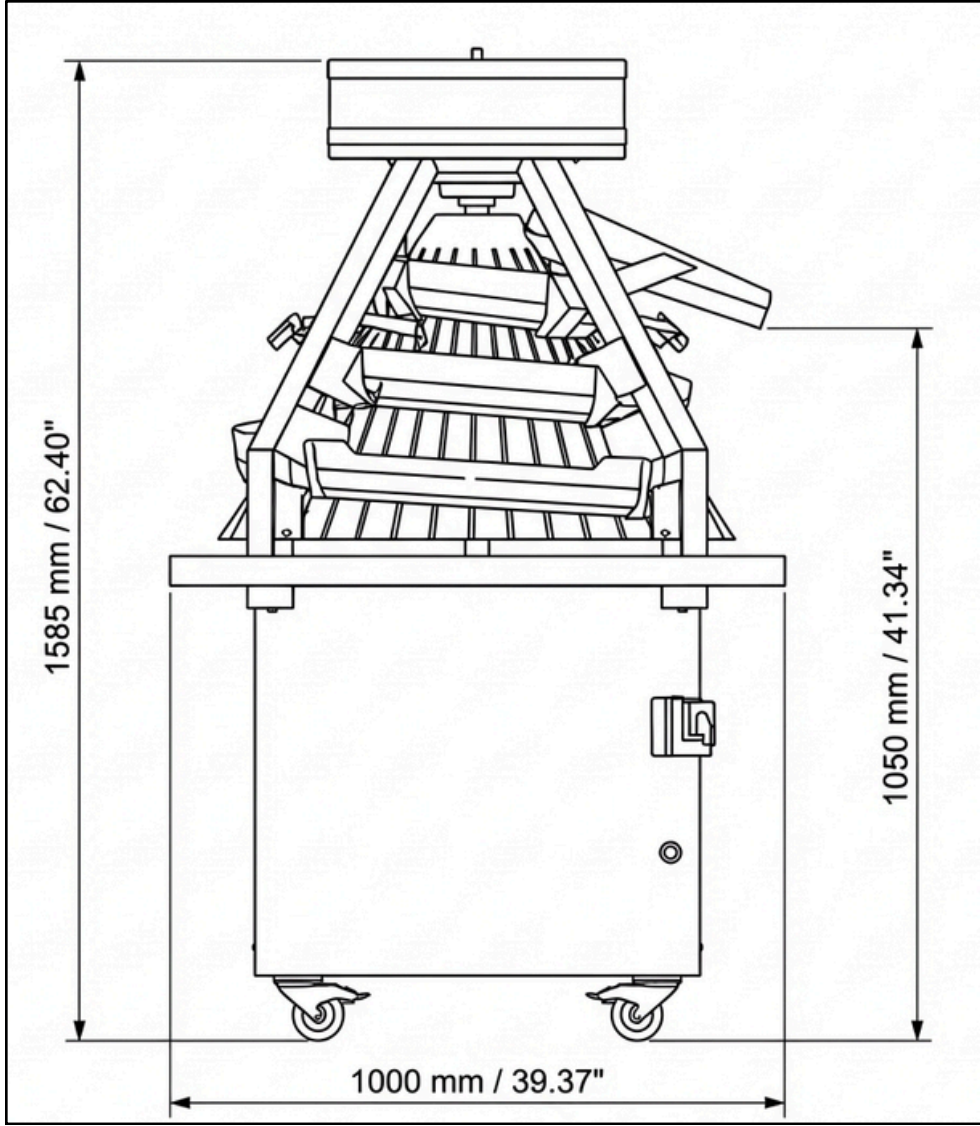

Parameter	mm	Inch
W	1000	39
L	1000	39
H	1585	62
h1	1050	41



TOLERANCE	UPDATE	Date
%1,00 +/-	2025	01.01.2020
notes		

Material	DIN
KG	N/A
Scale:	A4
Model Name :	
KYM 1600 -1800-2000-4800	
Model Nr.	KYM SERIES

CAD by ondermak - size and dimension scan be changed by producer

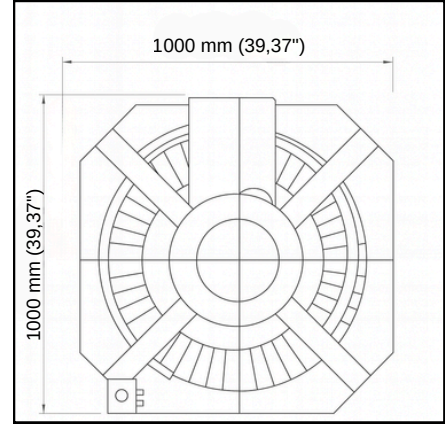
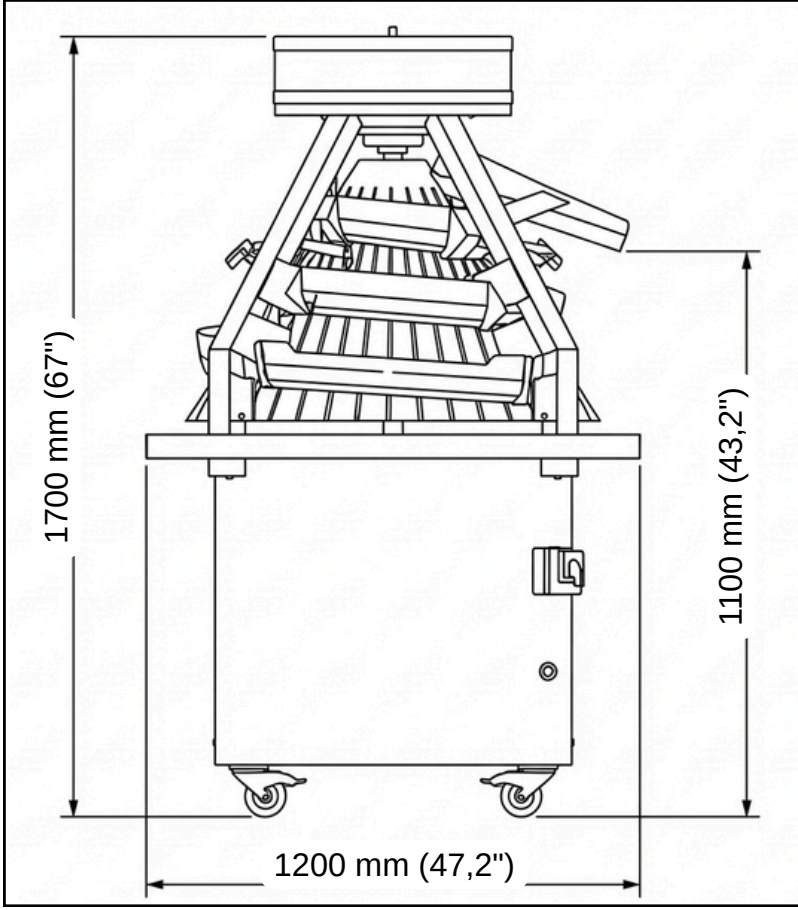

Parameter	mm	Inch
W	1200	47
L	1200	47
H	1700	67
h1	1100	43



TOLERANCE	UPDATE	Date
%1,00 +/-	2025	01.01.2020
notes		

Material	DIN
KG	N/A
Scale:	A4
Model Name : KYM PRO	
Model Nr. KYM PRO	

CAD

by ondermak - size and dimension scan be changed by producer



BOOSTED BAKERIES SINCE 1976

50th
ANNIVERSARY



Öndermak Bakery Equipment & Ovens

Eskişehir OSB 8. Cadde No:11 26110 - Eskişehir / Türkiye

Mobile & WhatsApp: +(90) 533 543 07 59

Mail: bilgi@ondermak.com.tr

Pbx: +(90) 222 236 08 03

Fax: +(90) 222 236 08 02

www.undermak.com.tr